

Minutes of the
Third Meeting of the SAD/YALINA-B Steering Committee (SC)
JINR Dubna, Frank Laboratory of Neutron Physics, June 27-28, 2005

- 1) The chairman of the SC, **C. Broeders**, welcomed the participants in the 3rd SC meeting. Before entering the agenda, he asked for a few moments of silence in memory of two excellent Russian scientists, participants to the 1. SC meeting in Dubna, who passed since then: **Dr. Y. Shubin**, a few days ago and Prof. **V. Barashenkov** in the fall of 2004. The picture in [Appendix 1](#) of Prof. V. Barashenkov, one of the initiators and promoters of the current SAD project, originates from the 1. SC meeting in Dubna. The list of participants is given in [Appendix 2](#). The proposed agenda was accepted ([Appendix 3](#))
- 2) **A. Sissakian**, JINR Director designate, welcomed the SCM3 participants. He underlined the important role of the SAD experiment in the roadmap of JINR development strategy with its strong international cooperation's. He stressed the importance of this SCM and wished a fruitful pleasant stay.
- 3) **W. Gudowski**, Chairman of the Contact Expert Group (CEG) for ISTC ADS and Transmutation Projects, informed about the current status of SAD/YALINA related activities, especially in connection with developments within the 6th. European Community Framework Program Integrated Project EUROTRANS. Because the ENEA Governing Board, end of 2004, did not approve the ENEA participation to IP EUROTRANS Domain 2 TRADE-PLUS, the content of a new program for the experimental support for coupling the components of a future ADS for nuclear waste incineration had to be redefined in a short time period. For this purpose an expert team was appointed to prepare a feasibility study for EUROTRANS Domain 2 ECATS "Experimental activities on the Coupling of an Accelerator, a spallation Target and a Sub-critical blanket". The SAD/YALINA SC members Broeders, Gonzalez and Gudowski participate to this expert group. At the 3rd ECATS meeting in Saclay on June 23 a first draft of the proposal was discussed. The SAD experiment will be part of ECATS program if official contracts between EC IP EUROTRANS and the other SAD partner JINR Dubna and ISTC Moscow concerning cooperation and commitments for funding will be signed in due time. W. Gudowski has a mandate to represent the IP EUROTRANS during discussions with ISTC Executive Director and JINR Director designate at the SAD/YALINA SCM3. Moreover, W. Gudowski reported about a meeting with B. Rhode, in charge of coordinating EC support to ISTC projects at the EC headquarters in Brussels. Although in general the funding for nuclear related projects in ISTC are decreasing, perspectives for continuation of funding of the relative expensive SAD experiment seem to be good. He stressed that extension of participation in SAD funding by other ISTC partner like USA and Japan would be very beneficial. Main objective of the current SCM is to prepare planning for SAD construction and experimental program in view of the participation to EC IP EUROTRANS.

- 4) The action plan of the SCM2 in Minsk was discussed on the basis of a copy of the corresponding part from the minutes of this meeting, with added comments ([Appendix 4](#)). All actions are completed or pending on schedule. Special attention was put on the ongoing general actions: target benchmark preparation, creation of group of young scientist to do experimental work in ADS area and preparation of IAEA CRP. It is foreseen that the first meeting of the IAEA CRP will be in the beginning of December 2005, probably together with a SAD/YALINA SCM.
- 5) The current status of the ISTC project #2267 SAD was presented in detail by **V. Shvetsov**, including timelines and cost estimates ([Appendix 5](#)). The project is very good on schedule. For successful continuation of the project SAD, 2 problem areas must be solved: funding of the quite high costs and availability of the PHASOTRON to deliver the required proton beam. For funding, a solution based on initially 1/3 funding each by JINR, ISTC and EUROTRANS, is intended. An unexpected problem is arised due to a fire in the PHASOTRON complex in the beginning of April 2005. This fire accident, caused by short-cut in high power supply with destruction of a number of cabling, was discussed in detail. The responsible persons for maintenance and reconstruction reported in detail about origin, extent and known consequences of the accident. Currently, it is not yet absolutely clear that reconstruction at reasonable costs will be possible. However, if no unexpected severe problems occur, recovering of the proton beam is planned for the end of 2006. It was also pointed out clearly that a main reason for fast recovering of the PHASOTRON proton beam is application for proton therapy purposes.
- 6) For the case of failing recovering of the PHASOTRON beam, alternatives for the SAD experiment were discussed. One possible solution could be to use the proton generator in Troitsk. This accelerator is now working at 200 MeV and can deliver higher beam power than PHASOTRON. The proton energy can be increased up till 500 MeV. Because of the JINR specific features of the SAD design, transposing SAD experiment to Troitsk seems not to be feasible. Moreover, in Troitsk the competence for performing such experiments is currently not available.
- 7) **A. Polanski** reviewed experiments on PHASOTRON connected with SAD project ([Appendix 6](#)). Concerning synergy effects between SAD/YALINA and other ISTC projects, collaboration with ISTC nuclear data experiments and experiments at BFS were discussed. Especially the possible role of BFS experiments related to SAD licensing and to measurement of SAD sub-criticality level was discussed in some detail. It was agreed that such BFS experiments, going from far sub-critical to critical, are highly recommended if they can be done at reasonable costs, either as separate ISTC project as proposed by A. Lopatkin or as part of SAD project.

- 8) **H. Kiyavitskaya** reported on “Booster (Cascade) Subcritical Assembly YALINA-B” ([Appendix 7](#)). The results obtained during ISTC project #B070 with YALINA experiment are now part of an IAEA benchmark investigation. Both experiments YALINA and YALINA-B will be integrated within the EUROTRANS DM2 ECATS. A MYRRHA–YALINA cooperation has already started. The proposal for a ISTC #B070 follow-up project is in preparation. It is proposed to start efforts to include the YALINA experiments in the "International Science Laboratory (ISL)", a joint scientific research venture between the Stepanov Institute (Minsk-Sosny, Belarus), the Fraunhofer Institute for Nondestructive Testing (Saarbrücken, Germany) and the International Science and Technology Center (ISTC).
- 9) The review of the SAD budget and the identification of different funding options for SAD, showed that it will be difficult to acquire funding for the SAD project:
- possible contribution of funding by JINR is restricted,
 - ISTC funding for nuclear projects is decreasing, contribution of additional partner to EC, e.g. USA and Japan is desirable,
 - EC IP EUROTRANS is willing to participate with a significant contribution if formal rules are fulfilled: written agreement documents between EURATOM/ EUROTRANS and responsible parties in Russia: JINR Dubna and ISTC.
- W. Gudowski** summarized that a cost partition of 1/3 each between the partner JINR, ISTC and EUROTRANS-ECATS has good perspectives for realization. This issue was also discussed in detail during the meeting with ISTC Executive Director N. Jousten and with JINR Director designate A. Sissakian on June 28.
- 10) **Y. Gohar**, ANL representative, reported about a STCU Partnership Project between US and Ukraine to couple a 100 kW electron beam with an existing water cooled sub-critical system with low enriched Uranium core at 100-130 kW for ADS investigations. The conceptual design phase is in progress.
- 11) **D. Villamarin** presented “Potential SAD activities with significant contribution from EU partners” ([Appendix 8](#)). Experiments in BFS and with the 660 MeV PHASOTRON beam are discussed. A. Stanculescu offered IAEA CRP as umbrella for proposed benchmarks in BFS and PHASOTRON. For the time of shut-down of PHASOTRON, EUROTRANS/ECATS target experiments with proton beams can be envisaged in the NUKLUTRON accelerator in Dubna
- 12) On June 28 a SAD/YALINA SC core group started preparing the required project planning documents for IP EUROTRANS DM2 ECATS. W. Gudowski agreed to take the lead to prepare this document together with C. Broeders. The basis for this work are a very preliminary proposal by D. Struwe, EUROTRANS/FZK, presented at ECATS meeting 3 in Saclay on June 23, the 2nd draft for this proposal and the presentation of D. Villamarin ([appendix 8](#)). D. Villamarin agreed to prepare the proposal for special actions for “Young Generation” in ECATS.

13) "Round Table" discussion with Management of JINR.

On June 28 SAD realisation was discussed in a "Round Table" session. Participants were: **C. Broeders**, **Y. Gohar**, **W. Gudowski**, **N. Jousten**, **F. Mellier**, **A. Polanski**, **L. Tocheny**, **V. Shvetsov**, **A. Sissakian (JINR Designated Director General)**, **A. Stanculescu**, **D. Villamarin**, **D. Shirkov (JINR-chief engineer)** and **A. Olshevsky (Director of the Laboratory of Nuclear Problems – PHASOTRON responsible)**. **A. Sissakian** welcomed the participants again and underlined the important role of the SAD experiment in the roadmap of JINR development strategy with its strong international cooperation's. After the participants introduced themselves, **W. Gudowski** made an extensive presentation of the current status of SAD/YALINA, ISTC and EUROTRANS/ECATS. YALINA is very good complementary to the MUSE experiment of EC FP5 and will be continued in EC FP6 EUROTRANS/ECATS. The SAD project, also linked to the MUSE activity, has been progressed very well and realisation may be envisaged in the next 4 years. The ISTC project #2267, preparation of the realisation with detailed planning, can be successfully completed in this year. For the practical realisation in Dubna 2 problem areas must be solved: financing and recovery of PHASATRON proton beam. Both aspects were discussed in detail:

a) Financing

The estimated total costs and the possible contributions of the partner were discussed in some detail. The differences between Russian full cost calculation model and ISTC payment, mainly for personal costs, was explained. ISTC cost model is more effective, but only can be applied for restricted tasks. **W. Gudowski** proposed the following partition:

- 1/3 JINR, Dubna, mainly for infrastructure
- 1/3 ISTC, mainly for personal costs in Russia and nuclear material parts, including fuel manufacturing
- 1/3 IP EUROTRANS/ECATS, mainly for experiment support and for broad participation of scientists from EC

At this stage no absolute numbers were discussed, but the expectation was expressed that detailed negotiations for real realisation of the project can lead to significant cost reduction. The discussion to solve the financing of SAD was very constructive:

- ISTC Executive Director **N. Jousten** reminded the possible options to realise the partial funding of the high costs of SAD. A document with commitments for such support can be provided in July 2005.
- JINR Director designate **A. Sissakian** confirmed the objectives of JINR to realise the SAD experiment in due time, including recovering of the PHASATRON proton beam. Written agreements between JINR Dubna and EUROTRANS representatives will be prepared in July 2005.

b) Recovering of PHASATRON proton beam

The fire accident in PHASATRON complex was explained in detail by **D. Shirkov (JINR-chief engineer)** and **A. Olshevsky (Director of the Laboratory of Nuclear Problems – PHASOTRON responsible)**. Currently, it is not yet absolutely clear that reconstruction at reasonable costs will be possible. However, if no unexpected severe problems occur, recovering of the proton beam is planned for the end of 2006. It was also pointed out clearly that a main reason for fast recovering of the PHASOTRON proton beam is application for proton therapy purposes. The round table discussion was followed by a common lunch.

- 14) The SCM meeting was finished with a short plenary session. **C. Broeders** and **W. Gudowski** reported the main results of the "Round Table Meeting". It was pointed out that preparation of the required documents for EC IP EUROTRANS DM2 ECATS must be completed with high priority.
- 15) The near term **action plan** ([Appendix 9](#)) is focused on integration of the SAD experiment in a broad international cooperation, specifically to ensure smooth continuation after successful completion of phase I end of 2005, with construction of the experiment with assured funding by JINR, ISTC (EC) and EC FP 6 EUROTRANS DM2 ECATS. Efforts will be undertaken to broaden the funding, e.g. by ISTC support from USA and Japan.
- 16) The 4. SAD/YALINA SCM will be held in the neighbourhood of an international airport to enable a one day meeting, without long transportation times. Currently preferred date is September 19, 2005 in Stockholm. Another SCM is envisaged in connection with an IAEA CRP meeting in Minsk in the beginning of December 2005.
- 17) With respect to revision of the list of members of the SAD/YALINA SC, the following proposals were accepted:
- a) Replacement of S. Chigrinov by H. Kiyavitskaya as representative of JIPNR-Sosny Minsk
 - b) Y. Gohar, ANL, agreed to become member of SC.
 - c) It was proposed to invite other international representatives: K Mishima, Japan and I. Bolshinsky, US DOE
 - d) It was proposed to nominate a second representative of Polish University, involved with experiments in Dubna.
 - e) It is proposed to nominate Hamid Ait Abderrahim from SCK-CEN Mol, Belgium.

18) Appendices

Appendix 1

In memory of Prof. Barashenkov, iniator of SAD



Go to [top](#)

Appendix 2

List of participants

C. Broeders, FZK Karlsruhe – chairman, broeders@irs.fzk.de
W. Gudowski, KTH Stockholm, wacek@neutron.kth.se
Y. Gohar, ANL, USA, gohar@anl.gov
A. Stanculescu, IAEA Vienna, a.stanculescu@IAEA.ORG
A. Lopatkin, NIKIET, Moscow, lopatkin@nikiet.ru
F. Mellier, CEA Cadarache, fmellier@cea.fr
A. Polanski, IPJ/JINR, polanski@ipj.gov.pl
V. Shvetsov, JINR Dubna, shv@jinr.ru
L. Tocheny, ISTC Moscow, techony@istc.ru
I.T. Tretyakov, NIKIET Moscow, tretjakov@nikiet.ru
V. Villamarin, CIEMAT Madrid, david.villamarin@ciemat.es
M.T. Vorontsov, GSPI
L.M. Onischenko, JINR Dubna, olm@jinr.ru
V. Batyaev, ITEP Moscow, vfb@itep.ru
Y. Titarenko, ITEP Moscow, yuri.titarenko@itep.ru
I.S. Golovnin, VNIIM Moscow, gis@bochvar.ru
L.I. Ponamarev, RRC Kurchatov Moscow, nucatex.leonid@g23.relcom.ru
S. Ivanov, VNIIM Moscow, isaev@bochvar.ru
A. Bobylev, Mayak
S. Elsoukov, Mayak
H. Kiyavitskaya, JIPNR-Sosny Minsk, anna@sosny.bas-net.by
I. Serafimovich, JIPNR-Sosny Minsk
A. Khilmanovich, JIPNR-Sosny Minsk,
Pepelysev, JINR Dubna, pepel@nf.jinr.ru
O. Strelalovsky, JINR Dubna, strekalo@se.jinr.ru
S. Petrochenkov, JINR Dubna, petrotch@jinr.ru

[Go to top](#)

Appendix 3

Agenda of the SAD/YALINA SCM3, Dubna, June 27-28, 2005

SAD/YALINA-B Steering Committee Third Meeting June 27-28, 2005

**Place: Frank Laboratory of Neutron Physics –
Conference hall**

Monday, June 27

9:00 – 9:15 Opening of the 3. SAD/YALINA-B SC Meeting, Approval of the Agenda

- Welcome by A. Sissakian, JINR Dubna
- W. Gudowski, Chairman CEG ISTC Projects ADS and Transmutation
- L. Tocheny, ISTC

9:15 – 9:30 Approval of the Minutes of 2nd SC Meeting in Minsk – C. Broeders

9:30 – 9:50 Review and discussion of Action Plan of 2nd SC Meeting – C. Broeders

9:50 – 13:00 Review of current projects:

9:50 – 11:00 Report on SAD status and progress, V. Shvetsov and others

With particular emphasis on:

- Cost assessment and uncertainties of the cost assessment
- Timelines for the project realization assuming ensured funding on an agreed level
- Possible visible showstoppers: assessment of licensing problems, priorities of the Institute etc.
- Consequences of the fire accident at PHASOTRON, plans for reconstructions, commitments of JINR,
- Review of experiments on PHASOTRON connected with SAD project
- Status of working group for SAD instrumentation support
- Status of Target Benchmark preparation
- Possible synergy with other on-going and planned ISTC projects

11:00 – 11:30 Coffee/Tea break

11:30 – 12:15 Report on YALINA status and planning.

YALINA as support experiment to SAD – A. Kiyavitskaya

12:15 – 13:00 Identification and discussion of critical issues of ongoing projects – all

13:00 – 14:15 LUNCH

14:15 – 16:15 Review of the SAD budget, identification of different funding options for SAD , with contributions of:

- JINR representative
- ISTC representative
- EUROTRANS representative
- DOE representative

16:15 – 16:45 Coffee/Tea break

16:45 – 17:30 Formulation of SAD tasks, workload, manpower which can be directly incorporated to ECATS. Assessing corresponding needs for the budget.

17:30 Adjourn

19:00 Dinner

Tuesday, June 28

8.30 – 11.00 Visit to the area for SAD experiment and YASNAPP building, discussion of core group of SC with JINR management

11:00 Meeting with ISTC Executive Director N. Jousten

12:30 – 14:00 Lunch

14:15 – 15:00 Organizational Issues + buffer time for continuation of Monday's program

15:00 – 15:40 Action plan for SAD project for coming 3 years – V. Shvetsov

15:40 – 16:00 Action plan for YALINA project for coming 3 years – A. Kiyavitskaya

16:00 – 16:30 Coffee/Tea time

16:30 – 17:15 Working/Action plan for supporting YALINA and SAD experiments

17:15 – 17:30 Action plan SAD-YALINA Steering Committee, updating list of SC members, date and place next meeting

17:30 Adjourn

19:00 Dinner

Go to [top](#)

Appendix 4

Action plan of the SAD/YALINA SCM2, Minsk, July 13, 2004

Comments on Action plan of SCM2

Action plan from the 2-nd SAD/YALINA SC meeting

- 1) SAD short term actions
 - a) Project time schedule with identified critical paths and milestones of special importance for EUROTRANS: 10 Feb. 2005 with 1-st draft distributed by Feb.6: responsible V. S. **(action closed)**
 - b) Cost assessment, linked to the TS, exploring ISTC funding and ISTC-channeling and "Russian template": 10 Feb. 2005 with 1-st draft distributed by Feb.6: responsible V. S. **(action closed)**
 - c) Cost assessment should be prepared according to the timeline with well defined parts for salary, design work, equipment manufacturing and construction work: responsible V. S. **(action closed)**
 - d) Template for the cost assessment will be kindly provided by H.A.A. by Jan.28 2005: responsible H.A.A. **(action closed)**
 - e) The document "White Paper", summarizing the objectives and the most important deliverables of the SAD. First draft to be prepared by Jan.31. This document will contribute to development of the "comparison table"/C.B./, which is the separate document, first circulation by Feb 1: final draft - Feb. 8 2005 responsible: C.B.&V.S. **(action closed)**
 - f) The additional funding options are to be explored for example: USA or Japan support for physical security system of SAD/V.S./, collaborators cofunding/SC members/, Japan and/or USA through ISTC/W.G, C.B. &V.S./. **(action pending)**
- 2) SAD management prepares request to ISTC executive director for current project prolongation caused by exchange rate effect till the end of 2005. **(action closed)**
- 3) SAD management prepares the ISTC application for the Phase II as a prolongation of the SAD project for the second GB meeting of 2005. **(action closed)**
- 4) Recommendation from the SC to the EUROTRANS committee on the SAD experiment: Jan 31, responsible: SC members **(action closed, short mission report by C.B.)**
- 5) SAD management prepares annual report on ISTC project #2267 with description of the SAD design by the end of Feb. 2005. **(action closed ?)**

6) YALINA actions

- a) Formal proposal for continuation of the YALINA experiment. The proposal should have strong synergy components with SAD: by the Feb. 15 2005, responsible S.Ch., V.S. & C.B. **(action closed)**
- b) Calibration of the YALINA detectors at MOL facility. Yu. Pepelyshev from SAD team participates this activity.: by June 30 2005, responsible: S.Ch. & H.A.A. **(action continuing)**

7) General actions

- a) The Polish group from UMM prepares benchmark on SAD target induced activity.: first input by the end of Feb. 2005, responsible: G.D. with intensive consulting needed from C.B.&E.G. **(action ongoing)**
- b) The SAD/YALINA collaborators create a group of young students/researchers/engineers to join experimental work on YALINA and SAD. The seed of this group already exists. **(action ongoing)**
- c) SAD/YALINA collaborators to submit proposals for Research agreements and Research contracts to IAEA for the CRP “...ADS benchmarking... ”.: by the end of Feb. 2005. **(action ongoing)**

Go to [top](#)

Appendix 5

Current status of ISTC Project #2267, SAD Experiment

SAD Project: Objectives, Tech. Description, Status, Cost Assessment

Third SAD/YALINA Steering Committee Meeting

SAD Project Objectives

- ✿ **Coupling all major components of ADS;**
- ✿ **Core design, safety assessment, licensing;**
- ✿ **k_{eff} control and monitoring;**
- ✿ **Shielding from high energy neutrons;**
- ✿ **Experiments on core neutronics, reactivity
feedbacks, transmutation reaction rates**

SAD Technical Description (participating organizations)

ISTC project #2267 was started at Nov 2003

- ✿ JINR - leading organization, scientific supervisor;**
- ✿ GSPI - the general designer;**
- ✿ NIKIET – subcritical blanket and target designer;**
- ✿ VNIINM - the developer of a fuel element;**
- ✿ IA “Mayak” - manufacturer of the fuel;**

About 180 people at present are working on project

SAD Technical Description (foreign collaborators)

- * Forschungszentrum Karlsruhe - FZK, Institut für Reaktorsicherheit, Dr. Cornelis Broeders;**
- * Kungliga Tekniska Högskolan - KTH, Nuclear and Reactor Physics, Dr. Wacław Gudowski;**
- * Centro de Investigaciones Energéticas Medioambientales y Technologies - CIEMAT , Dr. Enrique Miguel Gonzalez Romero;**
- * Commissariat à l'Énergie Atomique - CEA, Cadarache, Dr. Frederic Mellier;**

Basic Data

k_{eff}	~0,95
Fuel loading	< 420 kg
Fission power	27,6 kW
Cooling	air
Core	
Coolant flow rate, G	~ 0,6 kg/s
velocity, v	10 m/s
Pressure, P (<i>inlet</i>)	0,12-0,135 MPa
Temperature, T (<i>inlet, outlet</i>)	50/96 °C
Target (Pb)	
Coolant flow rate, G	~ 0,0067 kg/s
Velocity, v	50 m/s
Pressure, P (<i>inlet</i>)	0,12-0,135 MPa
Temperature, T (<i>inlet, outlet</i>)	50/125 °C

Subcritical Blanket/calculations

Number of cells for FAs	141
Number of loaded FAs	134
Number of loaded Pb prisms	7
fuel loading ($\text{UO}_2\text{-PuO}_2$)	396,9 kg
density of fuel	10,2 g/cm ³
PuO ₂ content in fuel	29,5 % (w.)
U enrichment	0,7 % (²³⁵ U)
Height of fuel	58 cm

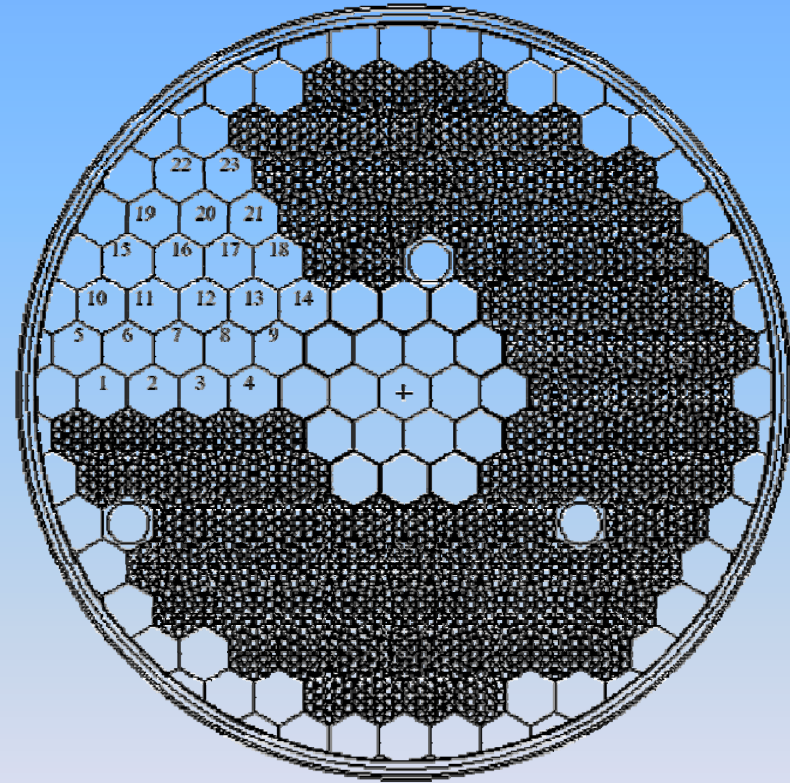

Subcritical Blanket/calculations

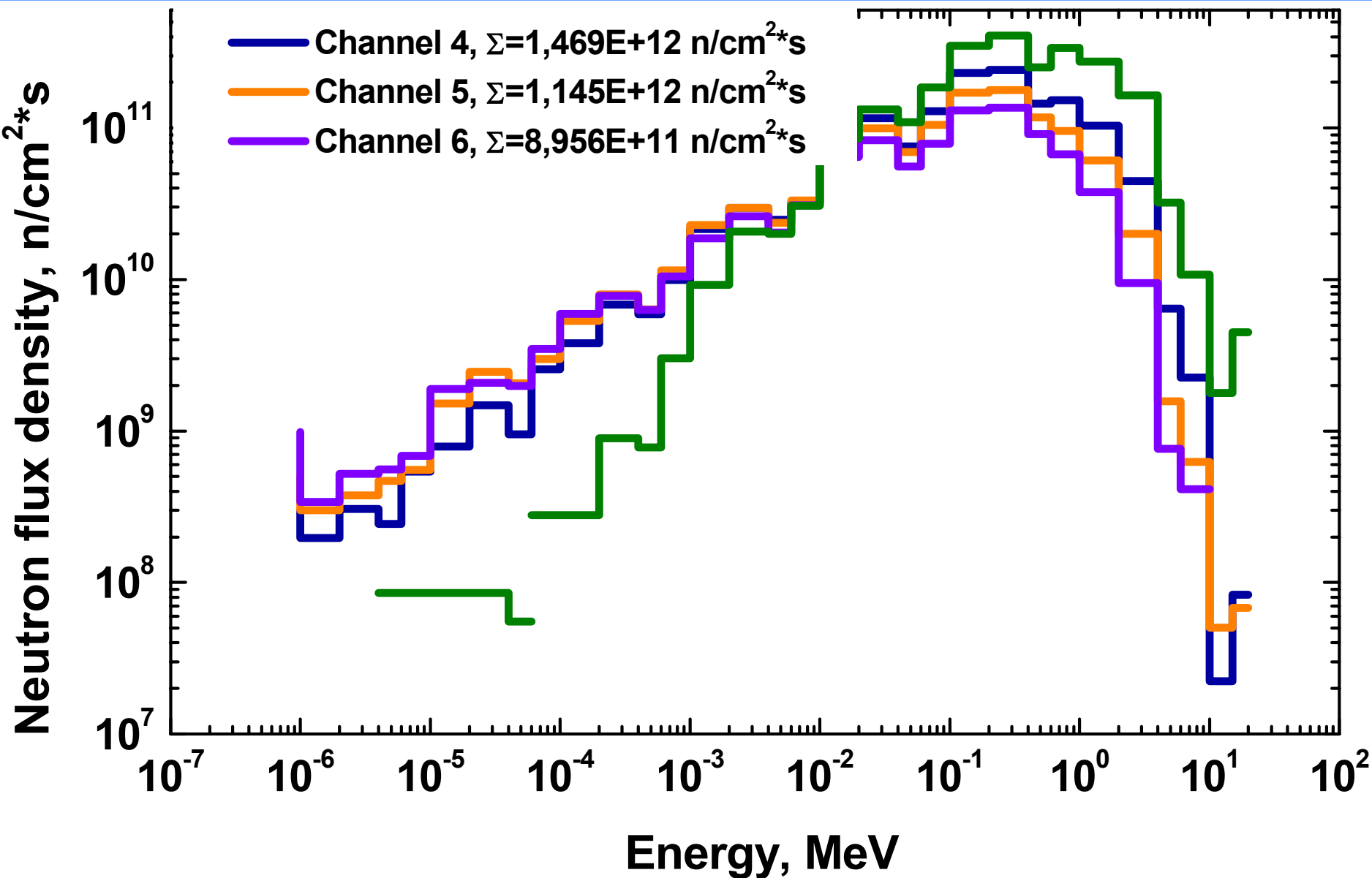

Subcritical Blanket/ neutronics

Calculated K_{eff}	0.9515
Neutron lifetime	$2.4 \cdot 10^{-5}$ s
Fission power	27.6 kW
Averaged neutron flux	$1.7 \cdot 10^{12}$ 1/(cm²·s)
Peak factor of heat generation (height)	1.21
<i>Heat generation in SAD parts:</i>	
Fuel	25.96 kW
Target (neutron and photon from fissions)	97.3 W
Core cladding	204.3 W
Side Pb reflector	565.4 W
B ₄ C	204.6 W
Concrete	771.1 W
Pu decay	~250 W
<i>Fuel</i>	
Max power density	18 W/cm³
Max flux of fast neutrons (E > 0,1 MeV)	$2.4 \cdot 10^{12}$ 1/(cm ² ·s)
Max fluence of fast neutrons	$8.0 \cdot 10^{19}$ 1/cm ²

Subcritical Blanket/design

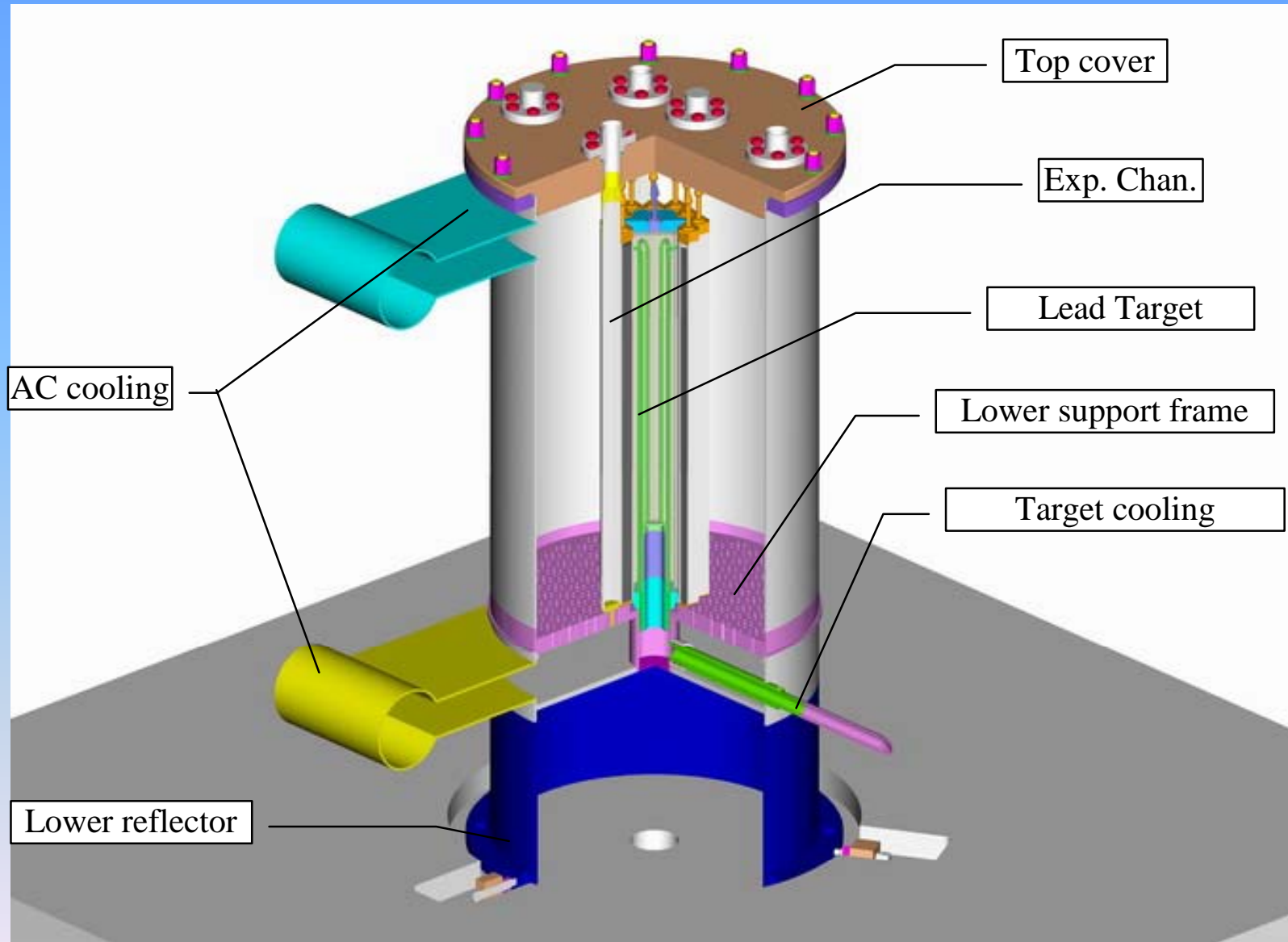

Cooling System

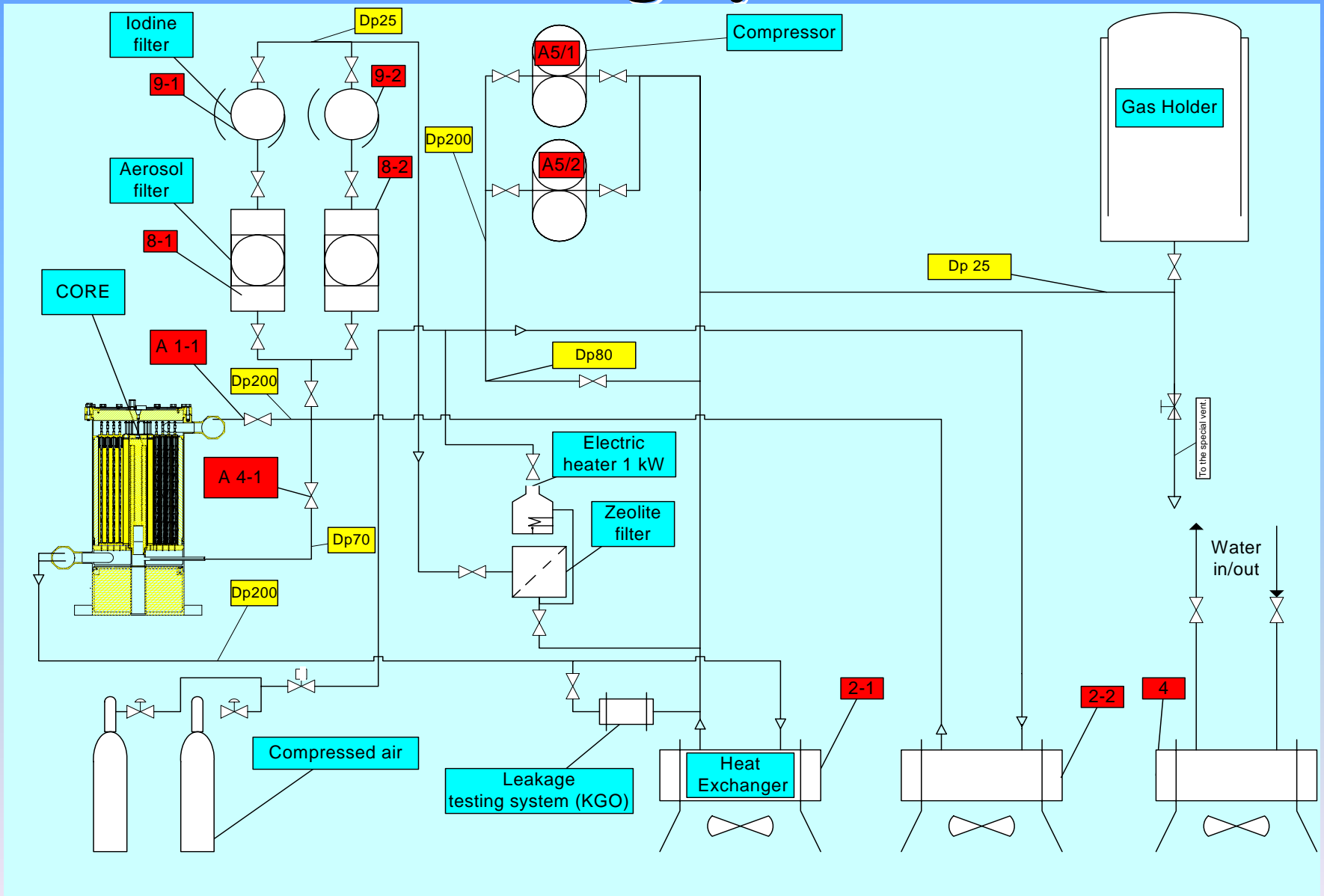

Target/design

Lead Prisms

Air Channels

Beam Input

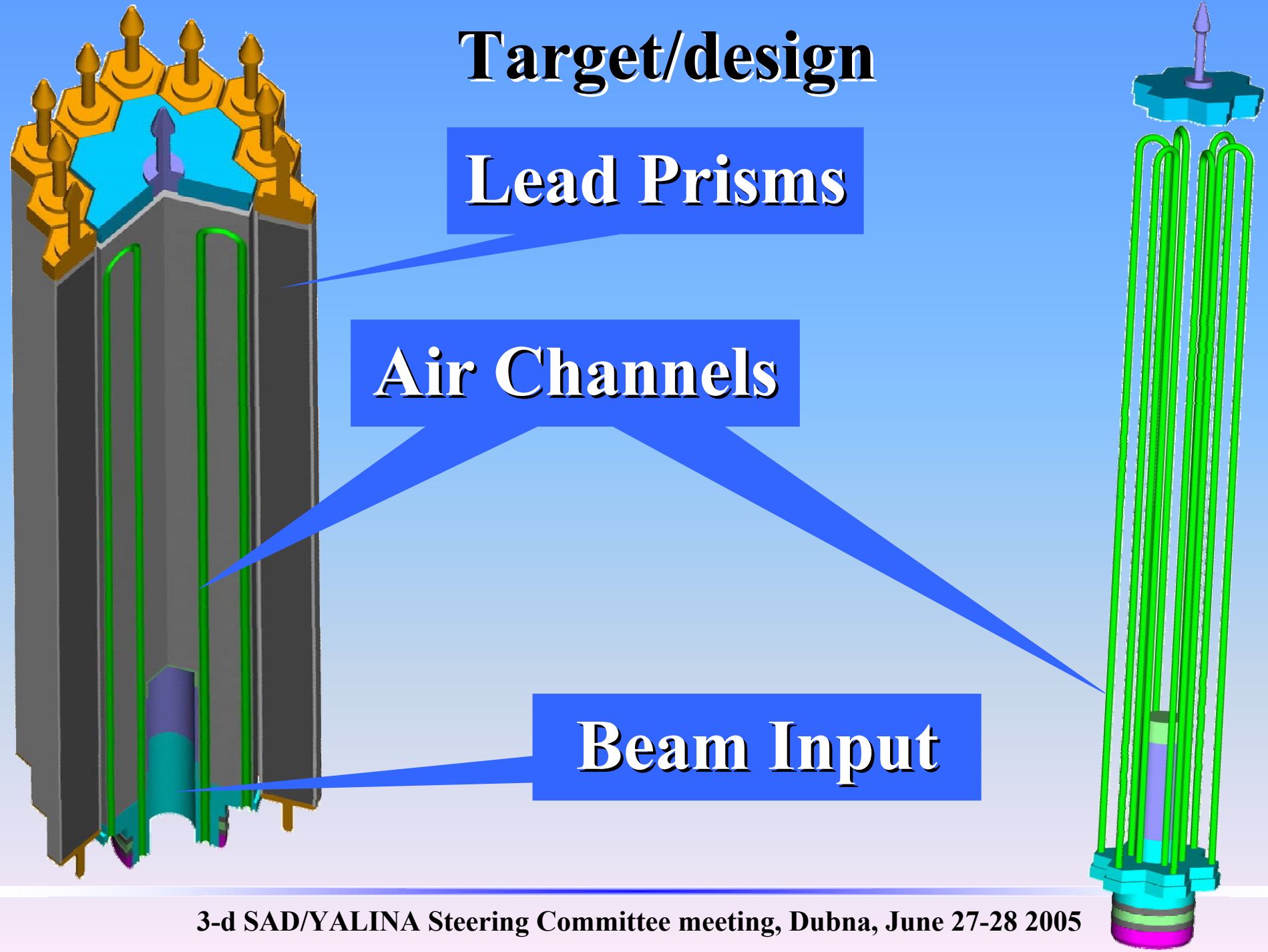

Target/neutronics

Proton beam

Energy 660 MeV

Beam power 1 kW

Target

neutron generation 12.95 n/p

total neutron leakage from target 12.73 n/p

side neutron leakage from target 12.22 n/p

total energy of leakage neutrons 103.2 MeV/p

total heat generation 840 W

neutron source for blanket **$1.143 \cdot 10^{14}$ n/s**

Phasotron Accelerator

Charged particles accelerated	Protons
Accelerator Type (linac, circular)	Circular (Phasotron)
Main accelerator sections and type of structures	180degree Dee
Source type	Internal, PIG type
Source Extraction voltage	Dee RF Voltage,40kV
RF system (amplifier characteristics)	Autogenerator,18.6-14.4MHz, 300kW
Magnet system (type, size, rigidity, homogeneity)	H-type, 6m pole diameter, 4spiral magnetic field 1.2T(r=0m) 1.63T(r=2.7m) average field, 0.3T(r=2.7m) 4th harmonic
Magnet Power Supply characteristics (current, stability, ramping, ...)	4000A, 0.05%stability
Total Power consumption	700kW
Cooling System	Distilled water cooling

Phasotron Accelerator

Beam Characteristics	
RF structure (RF frequency, phase width)	14.4MHz, 50degree
Macro pulse structure (filling of RF pulses)	250Hz rate, 20 mks FWHM
Long duration Beam Pulse characteristics (duty cycle, ...)	0.5%duty
Final beam energy	659MeV
Beam energy spread and stability	3.1MeV
Final beam intensity (average, peak)	3.2 mA average, about 1mA peak
Beam intensity stability	About 2%
Beam emittance at the high energy end	5.1pi*cm*mrad (horizontal), 3.4pi*cm*mrad (vertical)

Possibility to shorten the pulse width down to 1 mks is under investigation

Phasotron Accelerator



3-d SAD/YALINA Steering Committee meeting, Dubna, June 27-28 2005

Phasotron Accelerator



3-d SAD/YALINA Steering Committee meeting, Dubna, June 27-28 2005

Phasotron Accelerator

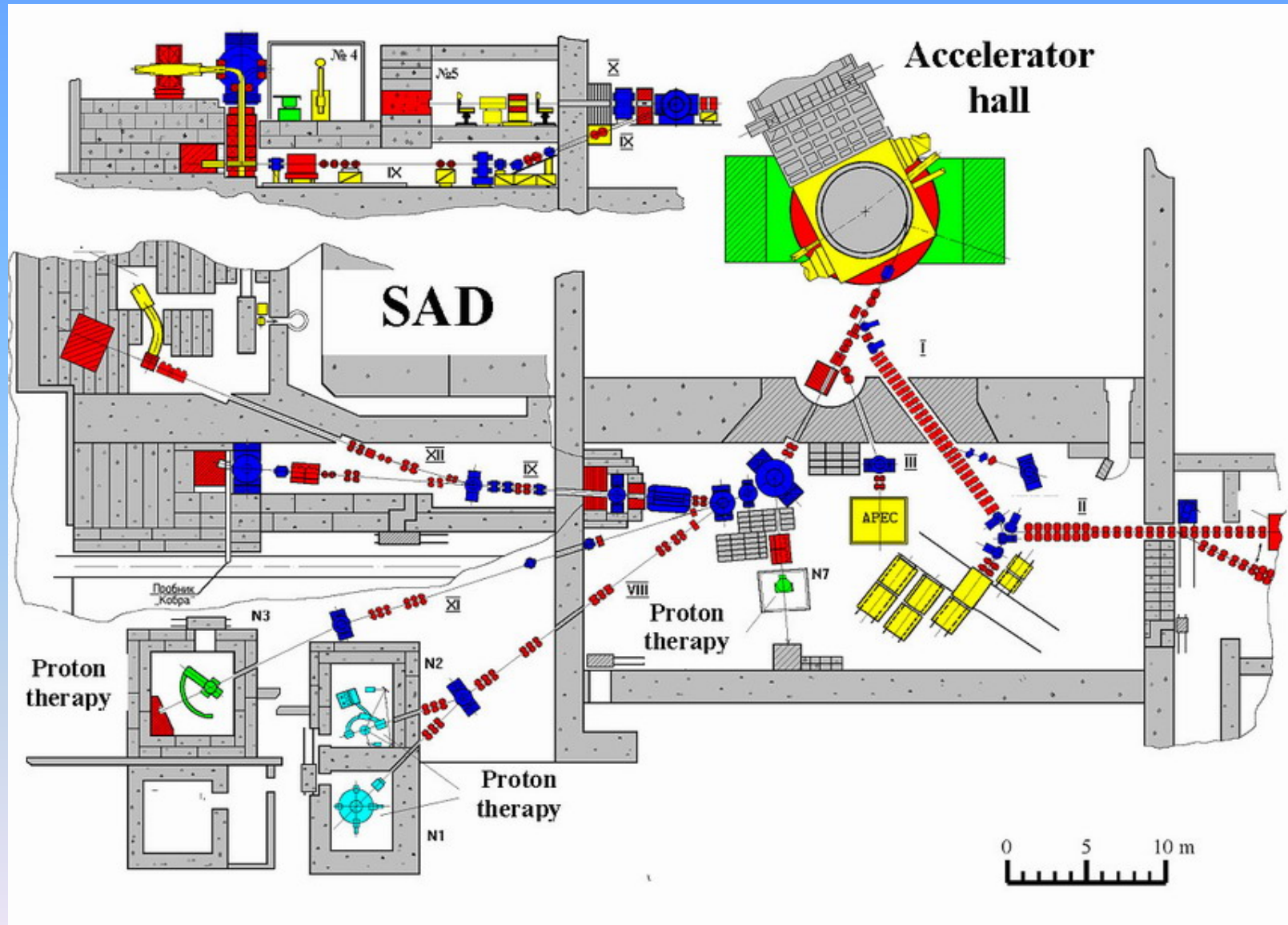

Тракт транспортировки протонного пучка к установке SAD

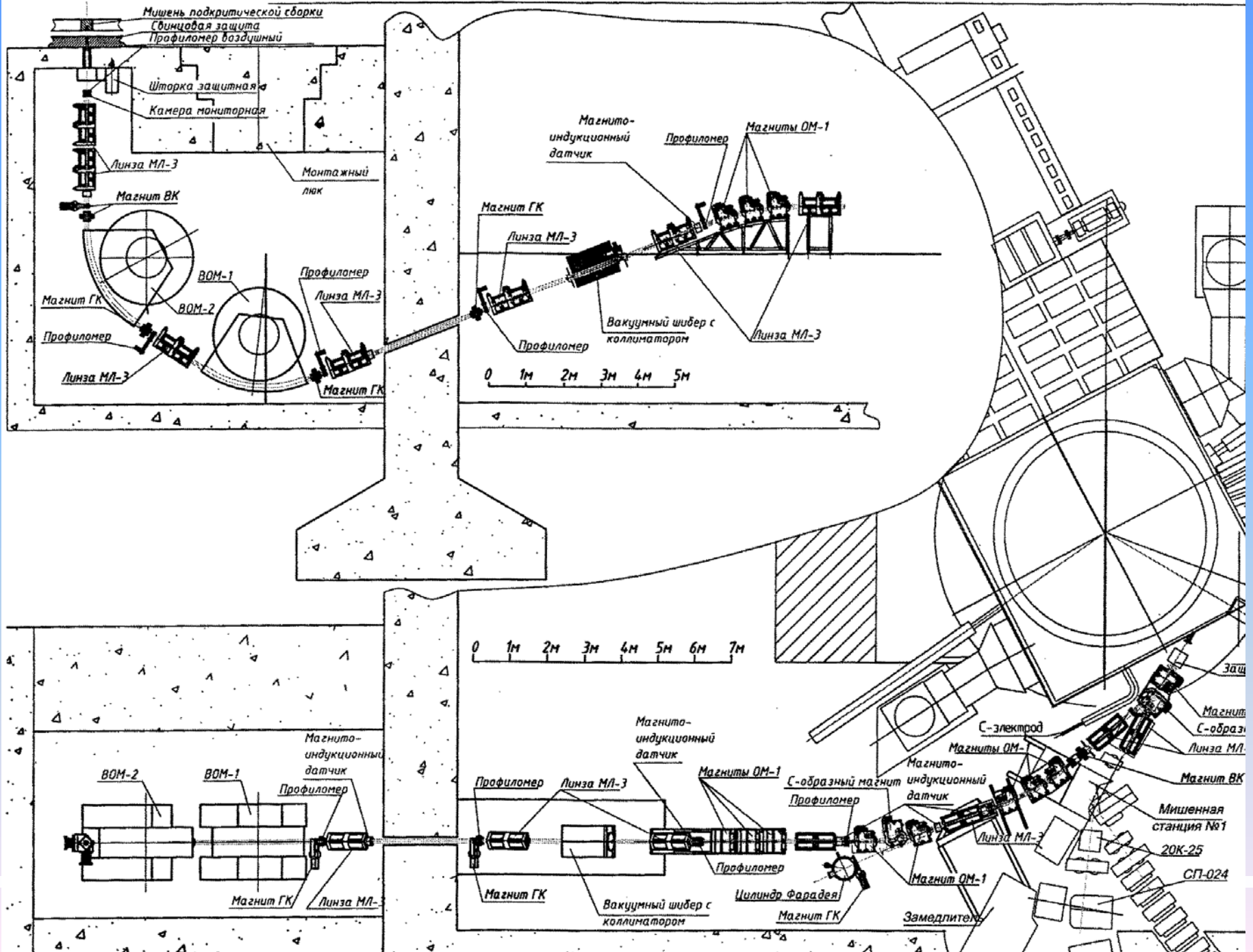

Initial data for SAD FE design

Operating Conditions

- ❖ **Maximum Dose for Constructional Materials of Fuel Element – 0.25 dpa.**
- ❖ **Fuel Maximum Burn up – 0.1 % h.a.**
- ❖ **Maximum Linear Power of Fuel Element – 0.275 kW/sm.**
- ❖ **Maximum Temperature of Fuel Element Cladding - 150°C.**
- ❖ **Core Coolant - Dry, Dust-free Air.**
- ❖ **Maximum Coolant Temperature at Core Output - 125°C.**
- ❖ **Fixed Resource of Fuel Element for Operation of Installation at Nominal Power (27 kW) – 10000 h.**
- ❖ **Fixed Core Lifetime of Fuel Element - 10 years.**

Processing Requirements for Fuel Element

- ❖ **Uranium and Plutonium Feed Powders, which are used for BN-600 MOX Fuel Fabrication.**
- ❖ **Constructional Materials of Standard BN-600 Fuel Elements.**
- ❖ **MOX Fuel Pellets Fabrication at “MAYAK”.**
- ❖ **Fuel Element Fabrication at “MAYAK”.**
- ❖ **Fuel Element Quality Control by “MAYAK” Control Procedures and Equipment.**
- ❖ **Components Fabrication at MSZ JSC.**

FE design

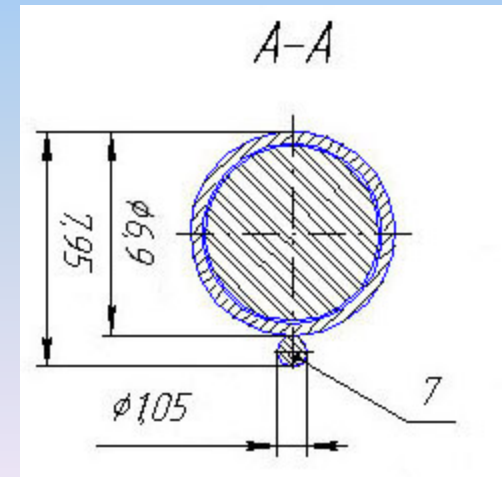
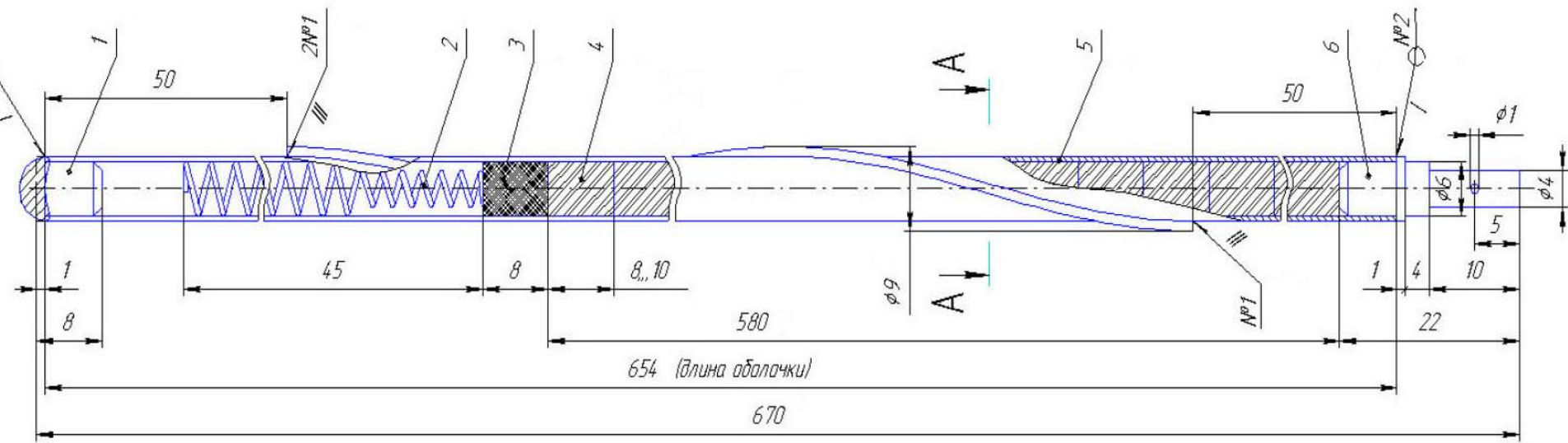

Fuel pellet

Mass share of U and Pu sum , %, not less	87.6
²³⁹Pu conditional mass in Pu dioxide, %, not less	95.0
²³⁵U conditional mass in U dioxide, % not more	0.7
Pu conditional mass share to U and Pu sum, %	30.0±0.3
Oxygen ratio	1.98
Density, g/sm³	10.4±0.2
Impurities mass share, %, not more	
Aluminium	0.02
Calcium	0.02
Magnesium	0.02
Iron	0.03
Silicon	0.02
Nickel	0.02
Chromium	0.02
Nitrogen	0.01
Carbon	0.01
Fluorine + Chlorine	0.005
Grain size, μm, not more	70

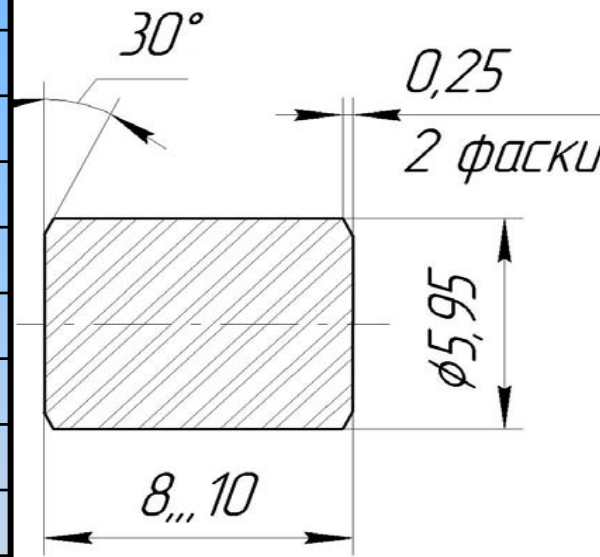

Pellets parameters control



Pu distribution homogeneity study

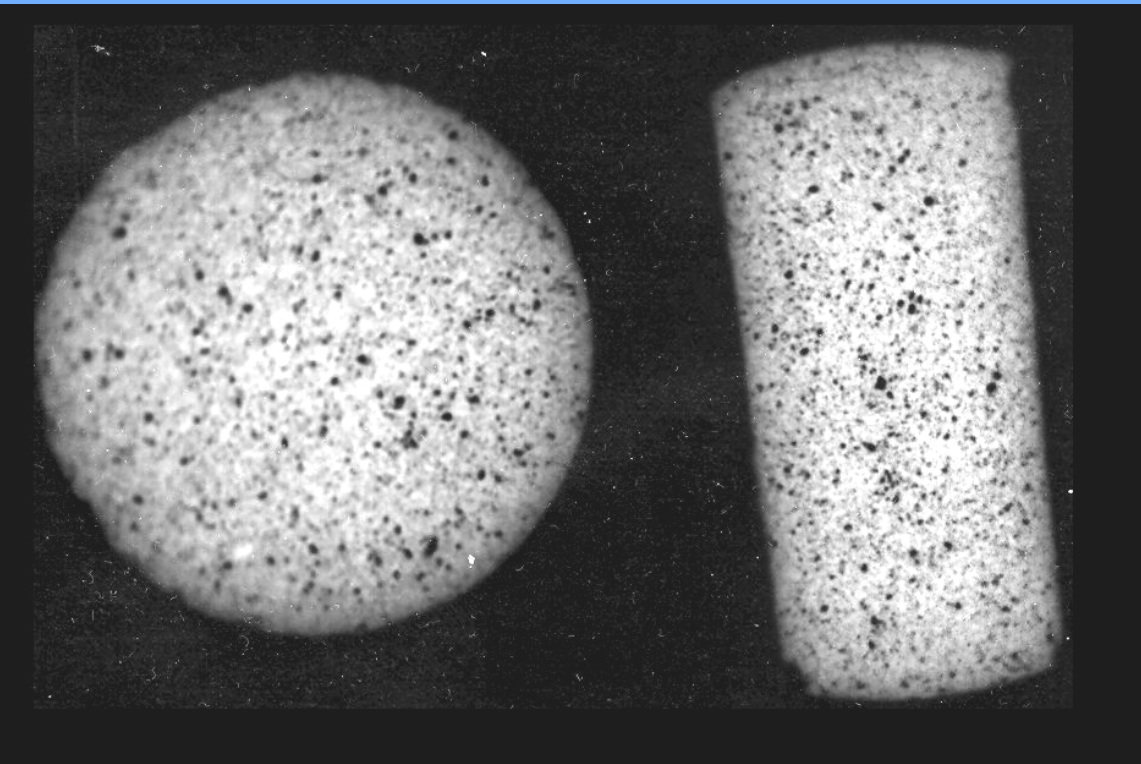

α -radiography

**Pu zones less
than 100
mkm in
diameter**

**Pu zones area less
than 10% of
microsection area**

No Pu zones observed here

Grain and pore dimensions

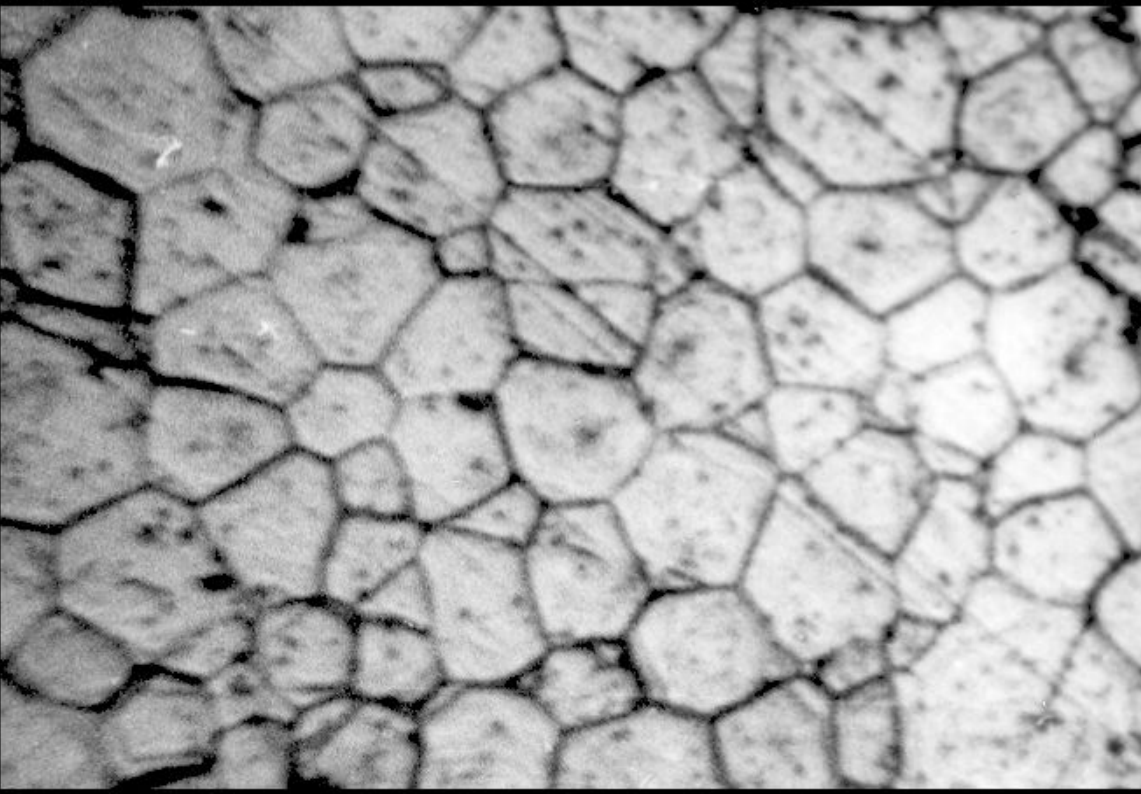

**Microscopy
study of the
microsections
processed in HNO_3
and HF acids**

**Pores diameter < 100
mkm and area less
than 10% of
microsection area**

**Grain diameter should be < 50
mkm (20-25 for that sample)**

General Layout

Shielding

Blanket

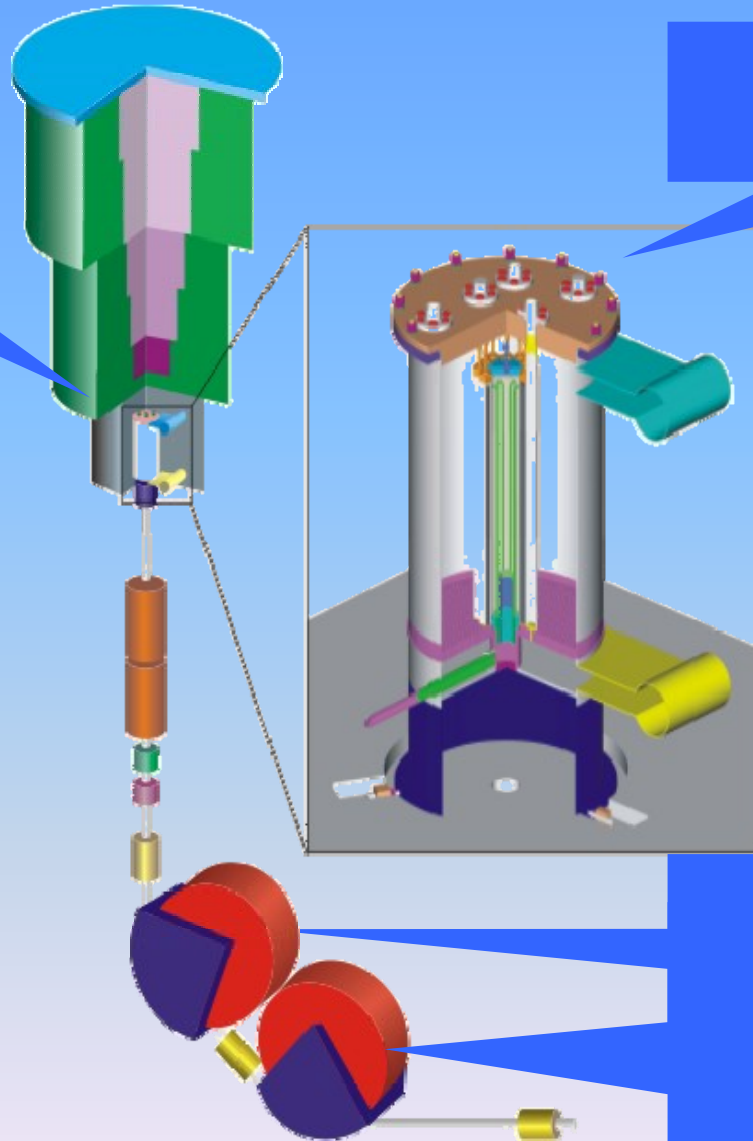

Vert.
magnets

General Layout

Parameter	Value
Site area, m ²	350
Total area, m ²	950
Building volume, m ³	8300
Bulk concrete volume, m ³	1900
Steel shielding, ton	290
Bulk heavy concrete volume, m ³	25
Soil shielding volume, m ³	2000
Excavated soil volume, m ³	4000
Concrete retaining wall necessary to dismount, m ³	350

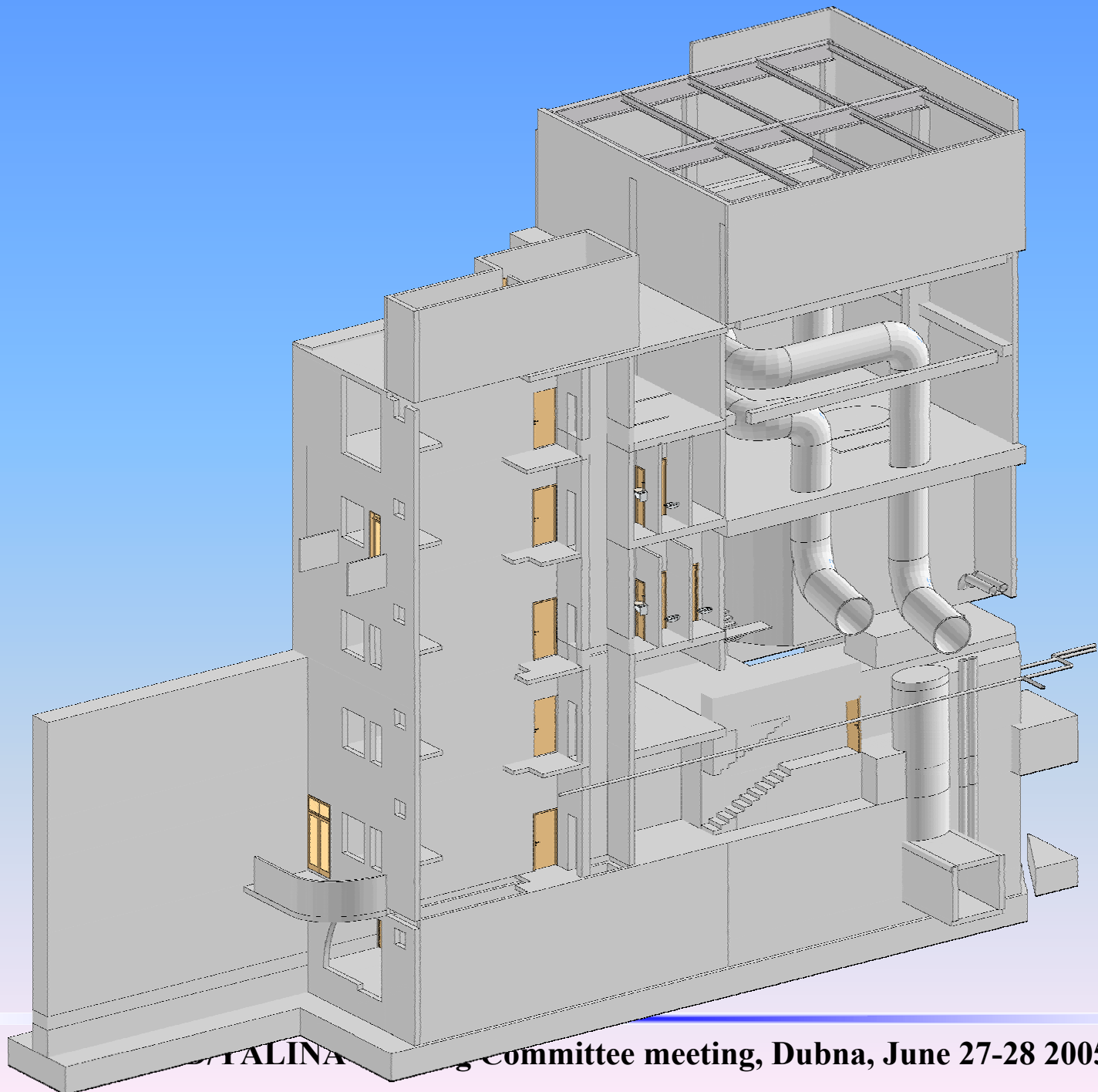

ATALINA ... committee meeting, Dubna, June 27-28 2005

Project Status

- ✿ **Technical project of the subcritical blanket: completed;**
 - ✿ **Technical project of the beam line: completed;**
 - ✿ **Technical project of the fuel element: completed;**
 - ✿ **Fuel pellets manufacturing technology: developed;**
 - ✿ **Preproduction batch of the fuel pellets: manufactured;**
 - ✿ **General engineering project: completed;**
- Licensing started some project documents already approved by Rostekhnadzor (former Gosatomnadzor)**

Project Timeline/licensing, blanket/

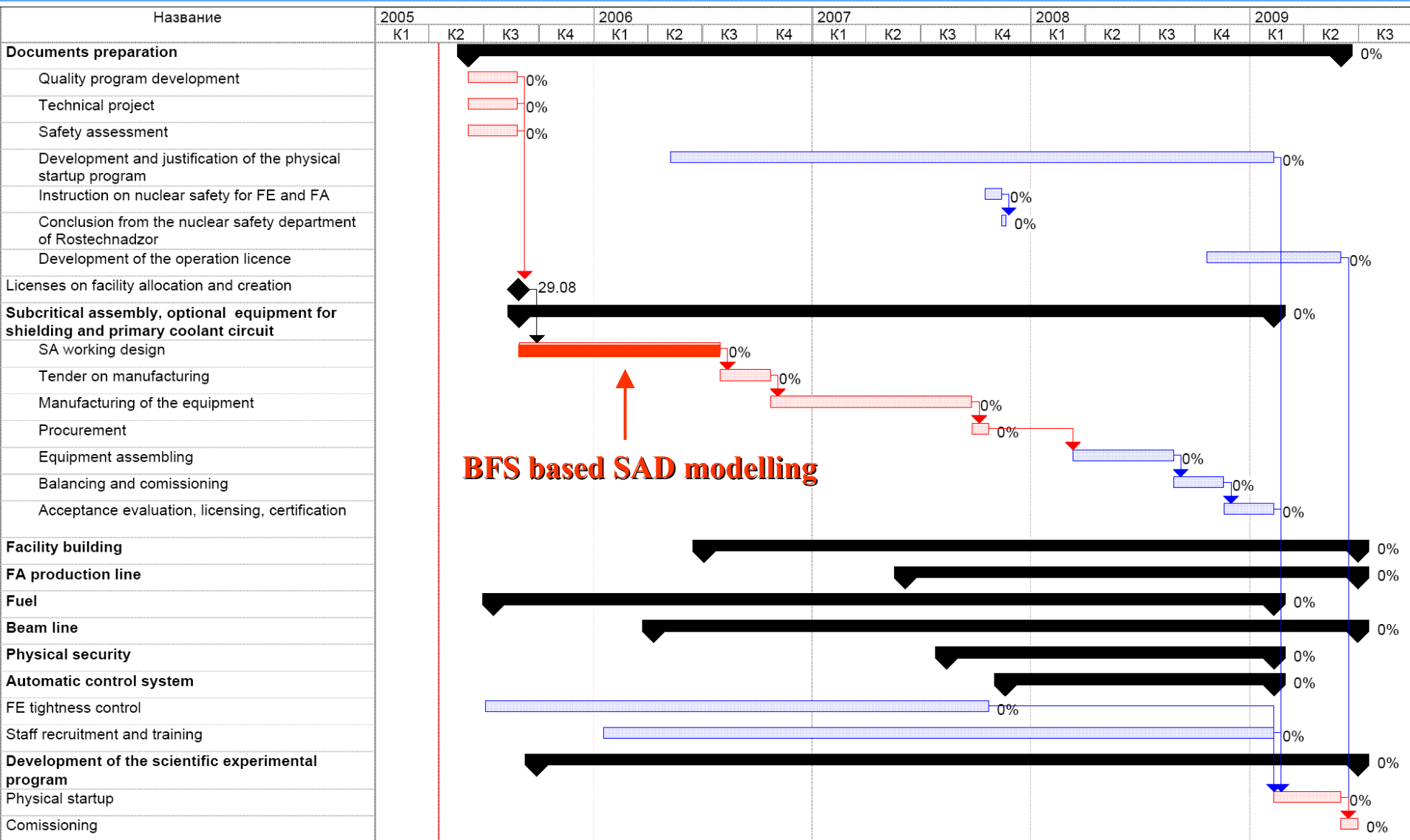

Project Timeline /building/

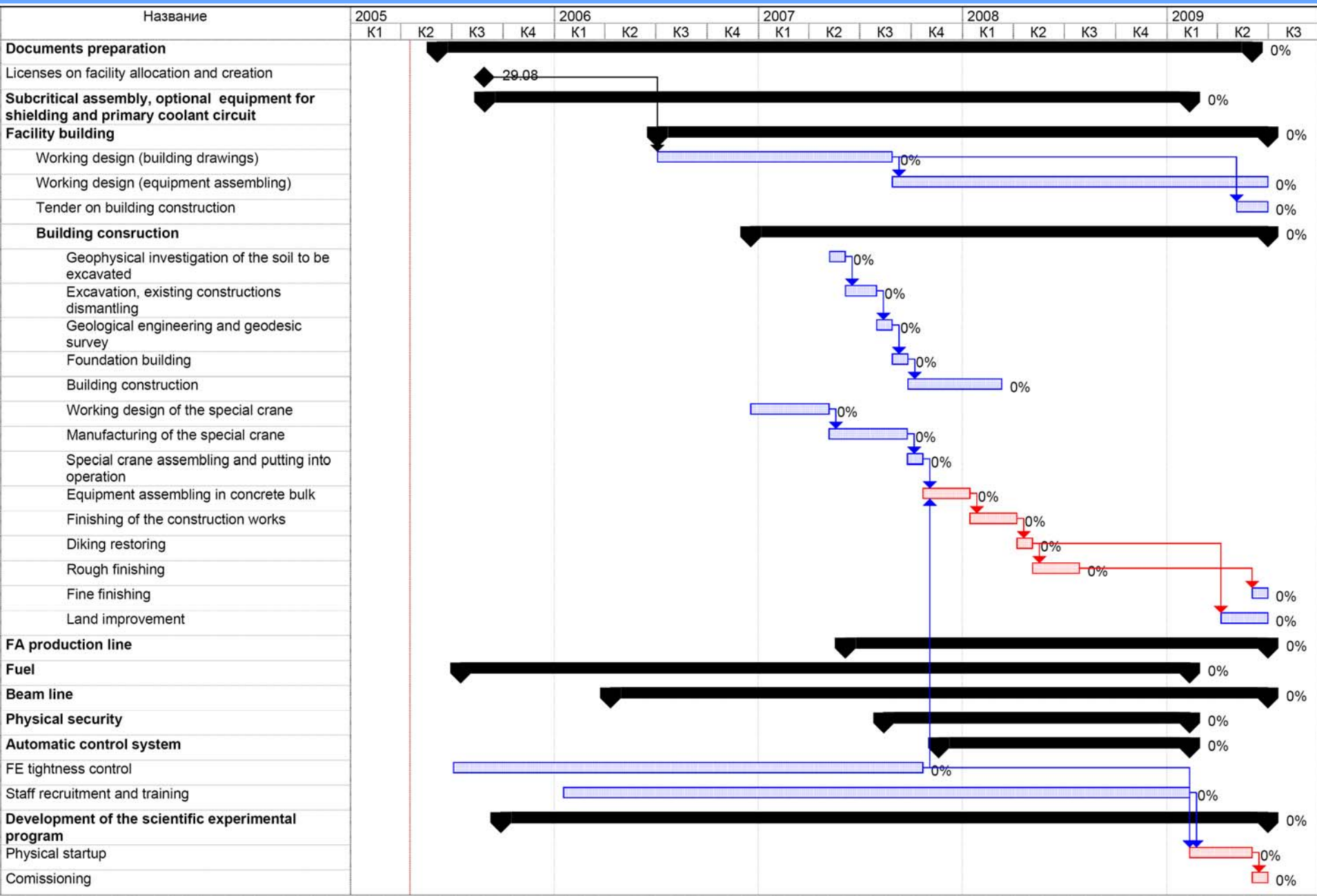

Project Timeline /FA production line/

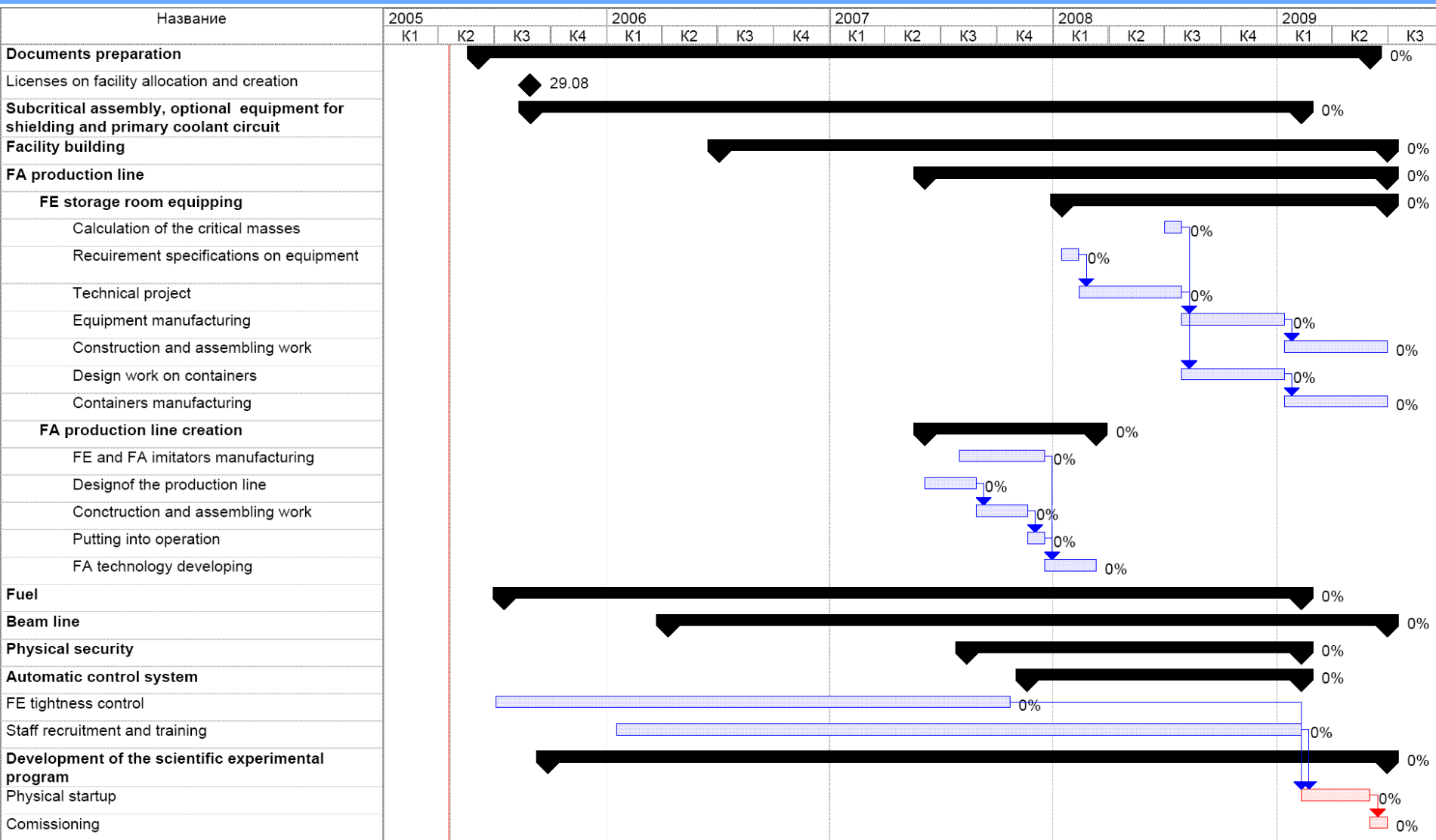

Project Timeline /fuel elements/

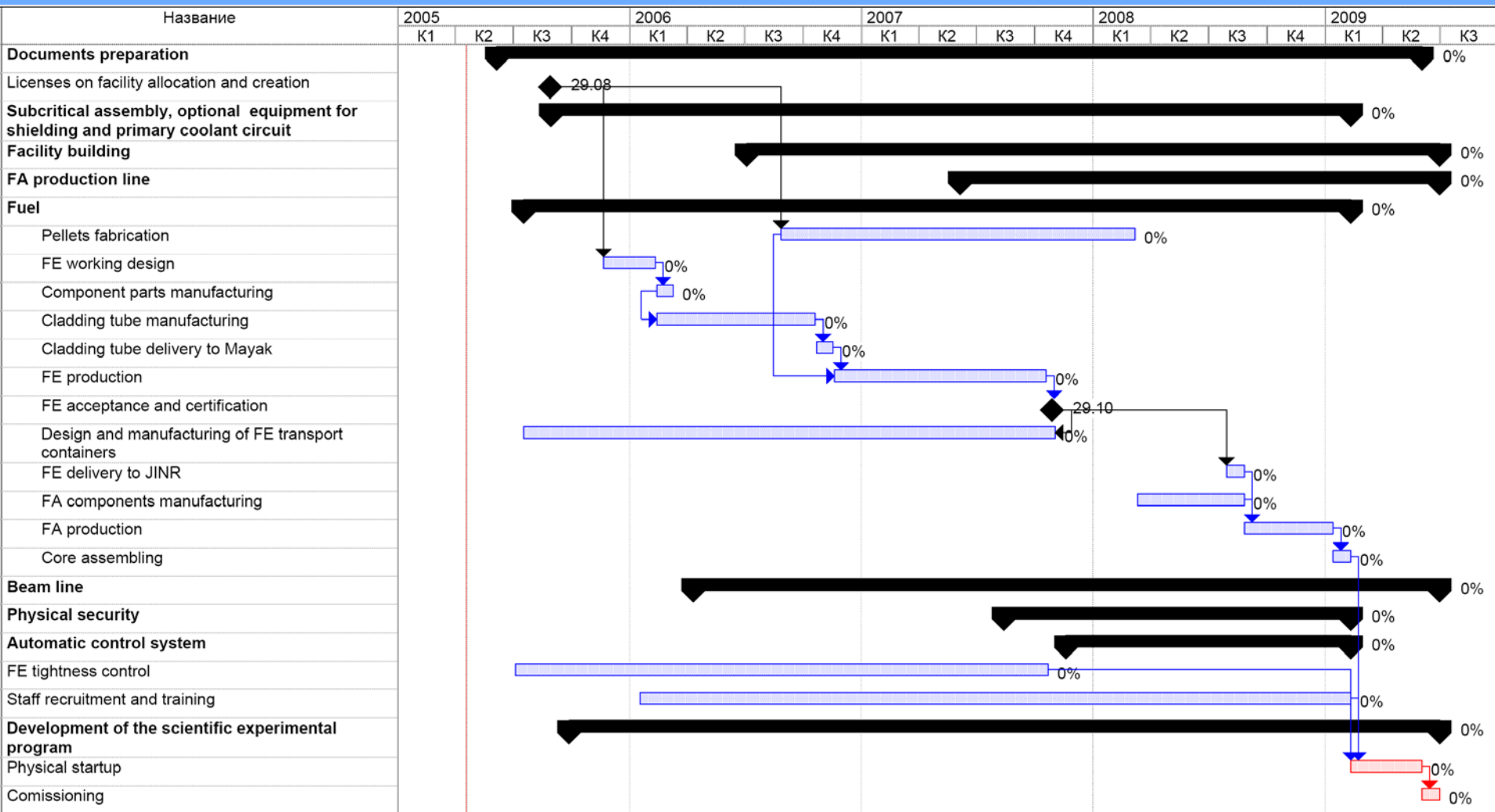

Project Timeline /ACS & exp./

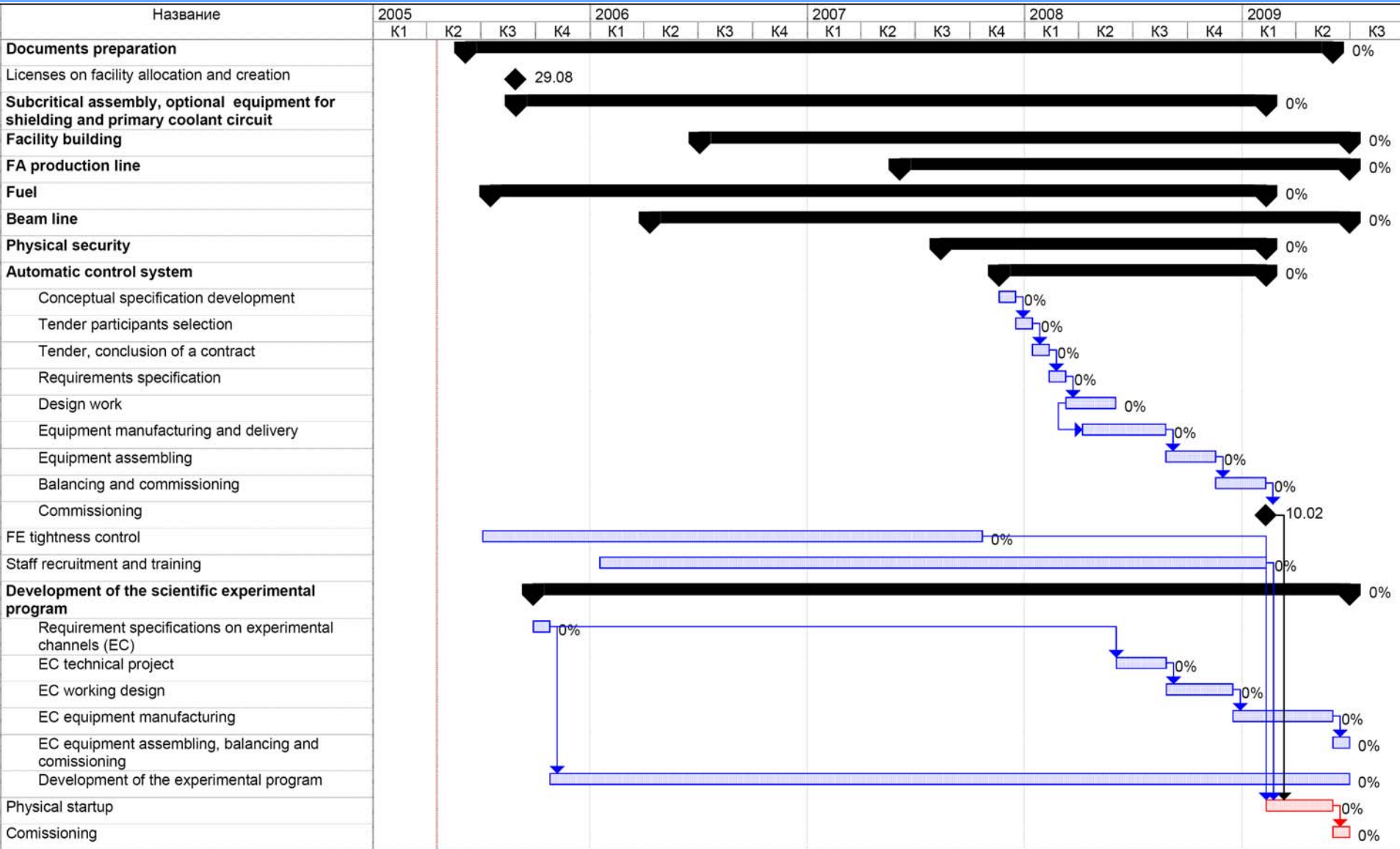

Project Timeline /crit. path: blanket/

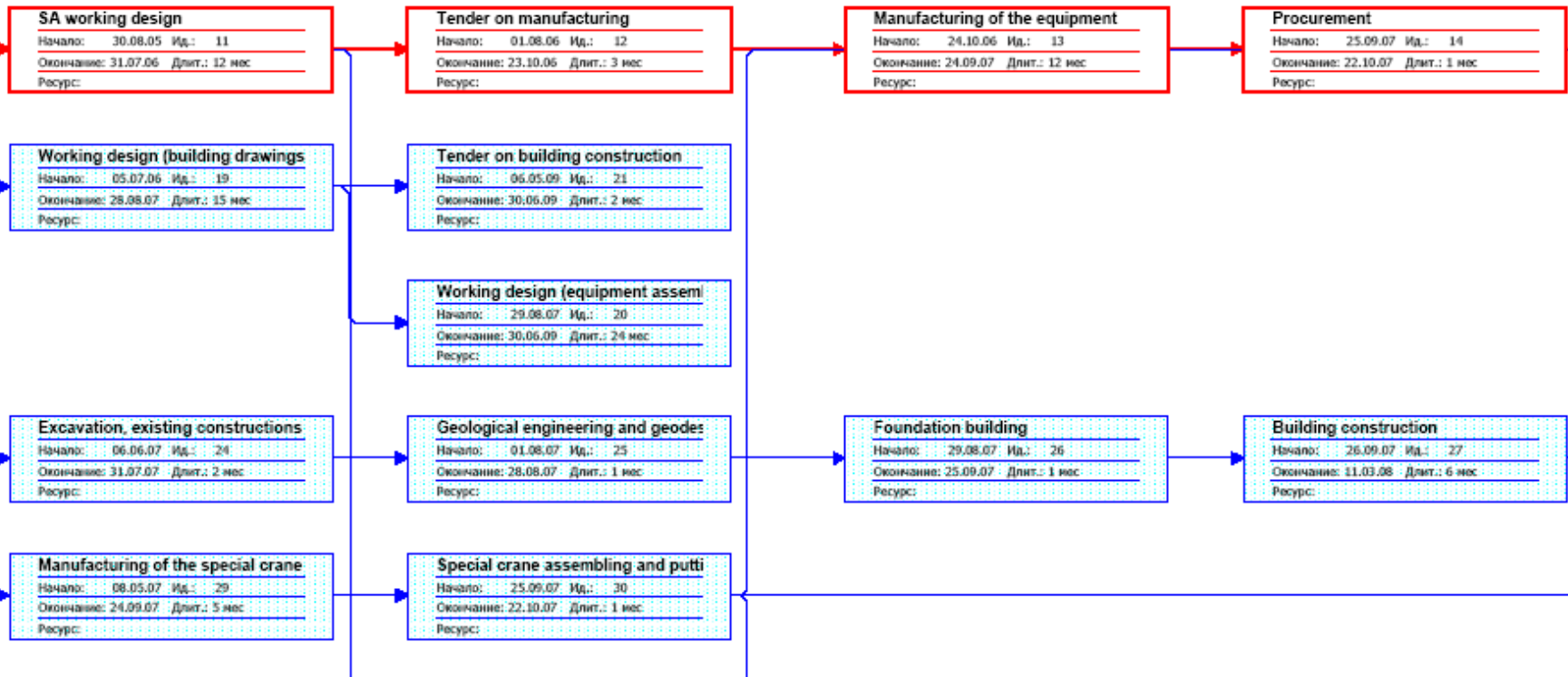

Project Timeline /crit. path: building and phys. sec./

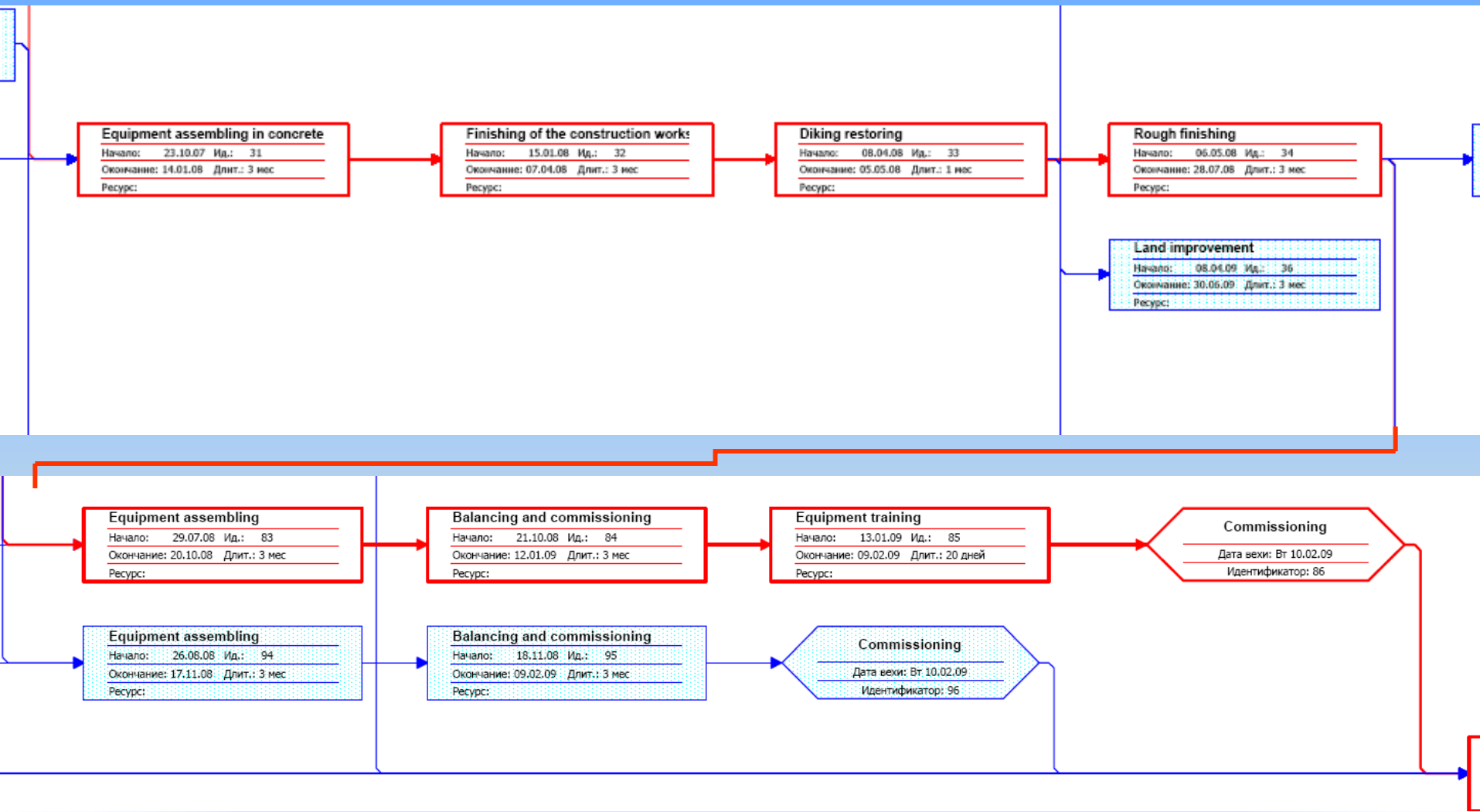

Cost assessment

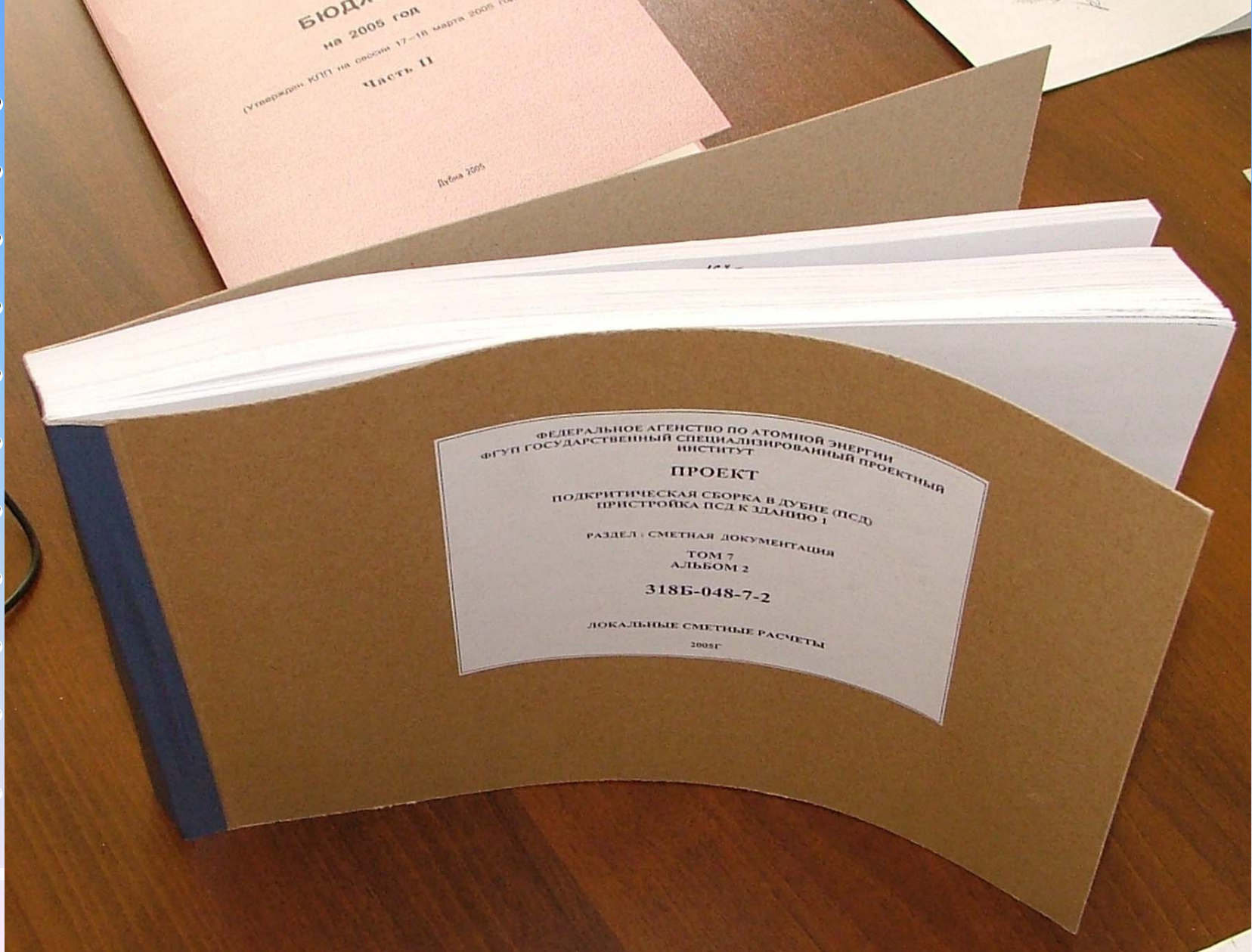

БЮДЖЕТ
на 2005 год
(Утвержден КГПТ на сессии 17-18 марта 2005 г.)
Часть II

Дубна 2005

ФЕДЕРАЛЬНОЕ АГЕНСТВО ПО АТОМНОЙ ЭНЕРГИИ
ФГУП ГОСУДАРСТВЕННЫЙ СПЕЦИАЛИЗИРОВАННЫЙ ПРОЕКТНЫЙ
ИНСТИТУТ
ПРОЕКТ
ПОДКРИТИЧЕСКАЯ СБОРКА В ДУБНЕ (ПСД)
ПРИСТРОЙКА ПСД К ЗДАНИЮ 1
РАЗДЕЛ : СМЕТНАЯ ДОКУМЕНТАЦИЯ
ТОМ 7
АЛЬБОМ 2
318Б-048-7-2
ЛОКАЛЬНЫЕ СМЕТНЫЕ РАСЧЕТЫ
2005Г

Go to [top](#)

Appendix 6

Review of experiments on PHASOTRON connected with SAD project

Subcritical Assembly in Dubna - Research Program for ADS-Demo Experiment.

*V.S. Buttsev , V.P. Bamblevski, C. Broeders, W.
Gudowski, J. Janczyszyn , A.R. Krylov,
I.V. Mirokhin, A.G. Molokanov, S. Petrochenkov,
A.Polanski , W. Pohorecki, V.N. Shvetsov , G.N.
Timoshenko.*

Research Program for ADS-Demo Experiment.

1. Studying the heat generation and neutron flux in the target and experimental channels for different target materials and different position of the target in the subcritical assembly.

Beam profile will be measured with Al activation detectors, matrix of thermoluminescent detectors and profilometer.

Gross section for $Y=0.25$ cm

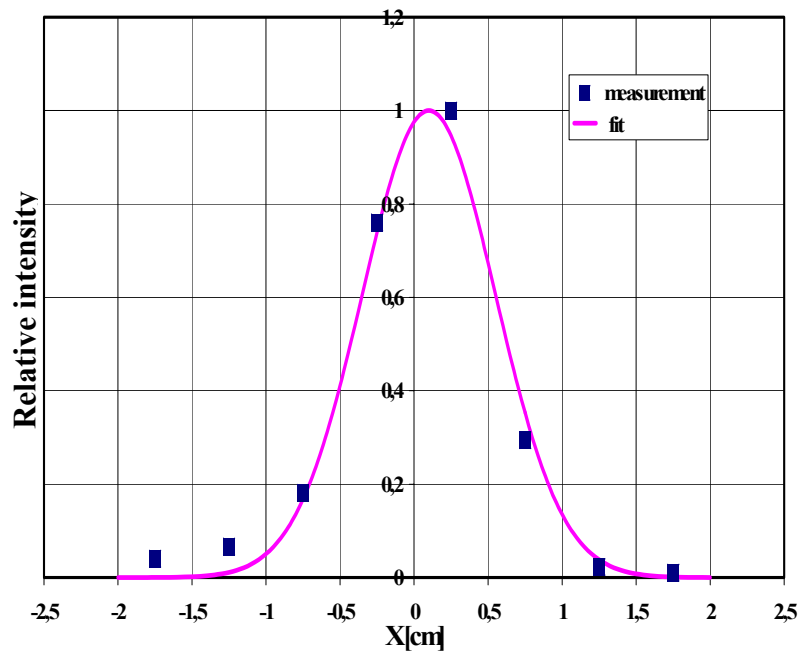

Gross section for $X=0.25$ cm

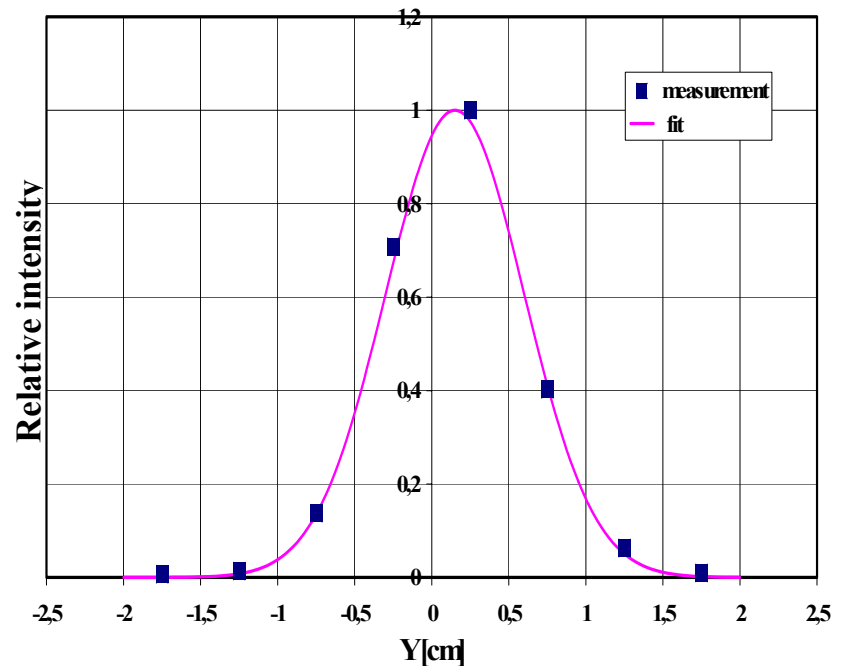

Particular attention will be given to validation of the core power/beam current relationship

- Power level will be monitored by two certified channels with 3 neutron sensors (high sensitivity fission chamber, low sensitivity fission chamber; boron current chamber)
- To investigate neutron field in fast energy region absolute reaction rates will be determined for ^{12}C , ^{27}Al , ^{59}Co , ^{64}Cu , ^{115}In , ^{197}Au , ^{209}Bi .

2. Study of distributions of the radionuclides activity induced in the target.

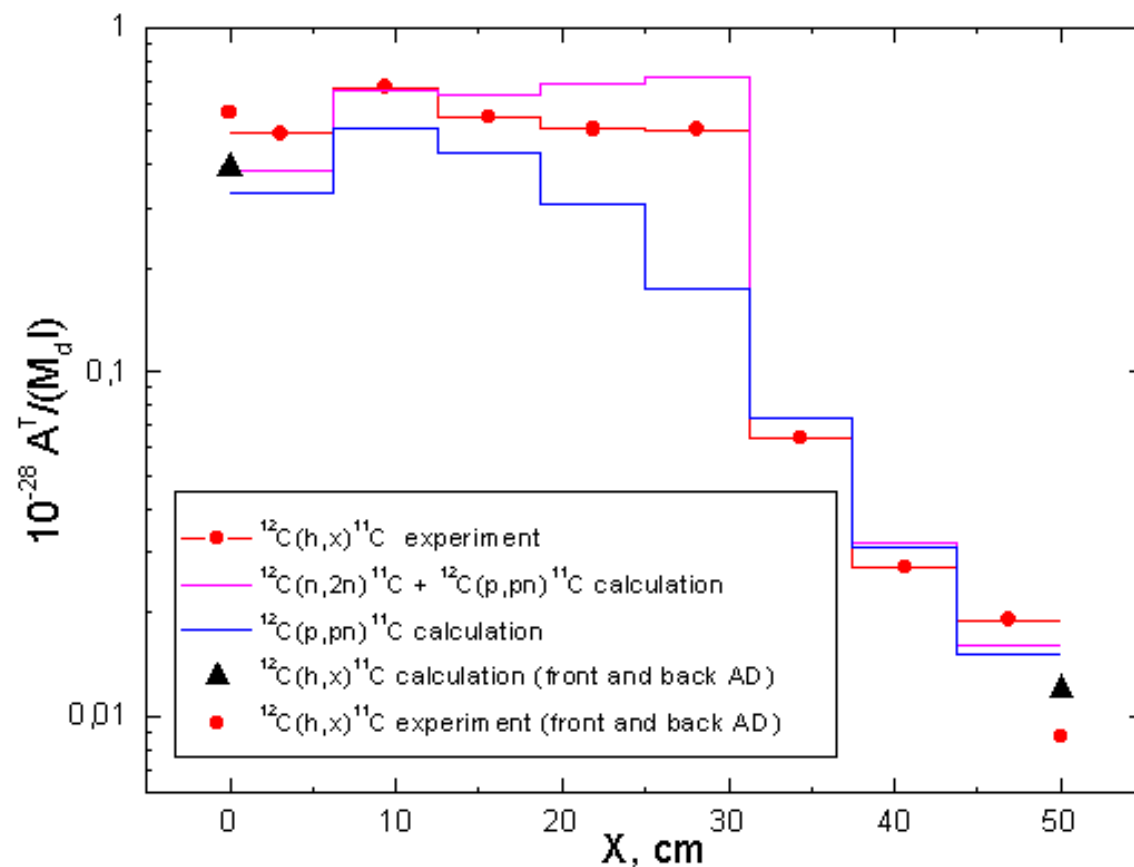

Study of distributions of the radionuclides activity induced in the target.

- SAD will have a replacable spallation target Pb and W options are foreseen with different sizes, changeable proton spot-point and different beam shapes.
- To investigate of proton and neutron field and activity in spalation target reaction rates will be determined for ^{12}C , ^{27}Al , ^{59}Co , ^{64}Cu , ^{115}In , ^{197}Au , ^{209}Bi and target samples, Pb and W.

3. Study of kinetic properties of multiplication coefficient fluctuation of subcritical electronuclear system.

- In SAD scientific program it is proposed to pay attention for experiments on measurements and monitoring of the k_{eff} . It is planned to measure k_{eff} average value by means of inverse multiplication, asymptotic period and other techniques.

4. Investigation of the neutron spectra and formation of residual nuclei from the radioactive ^{99}Tc , ^{129}I , ^{135}Cs , ^{237}Np , ^{241}Am , ^{243}Am samples.

- Small samples of ^{99}Tc , ^{129}I , ^{135}Cs , ^{237}Np , ^{241}Am , ^{243}Am will be exposed in experimental channels. The (n, γ) and (n,f) transmutation rates will be determined for these nuclides.

5. Investigation of neutron and proton spectrum across and behind lead reflector and concrete shield.

- In the neutron-shielding experiment, we usually use the activation methods using the simple reactions, such as $^{209}\text{Bi}(n, xn)^{209-x}\text{Bi}$, $^{27}\text{Al}(n, \alpha)^{24}\text{Na}$ and spallation products on ^{197}Au target.

5. Investigation of neutron and proton spectrum across and behind lead reflector and concrete shield.

Comparison of Calculated and Experimental Neutron Spectra from Pb-target at 105°

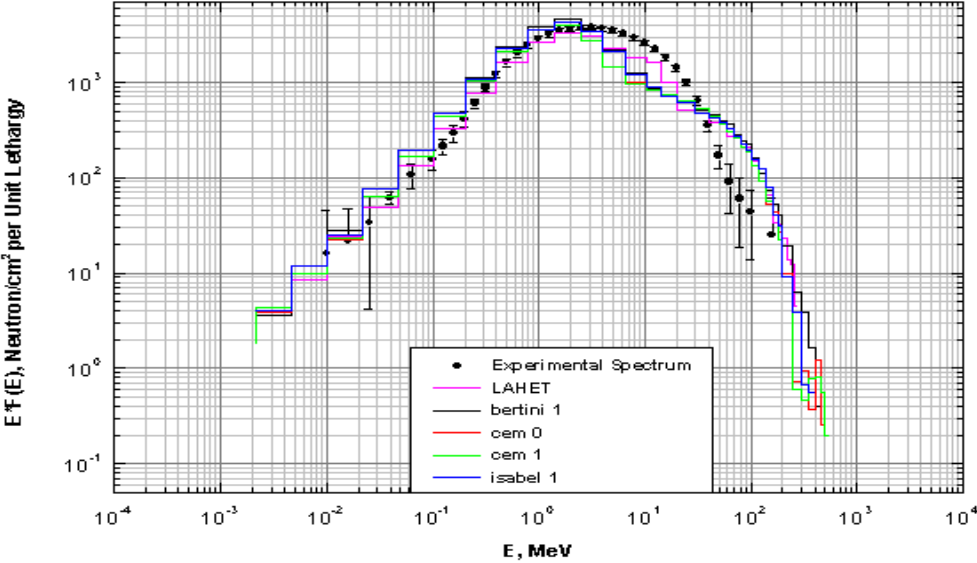

Comparison of experimental results of the neutron spectra measurements at different angles with computer simulations of LAHET and MCNPX using different options for a high-energy

Comparison of neutron spectra for different K_{eff} (0.952 for 133 TVS and 0.972 for 141 TVS) in experimental channel.

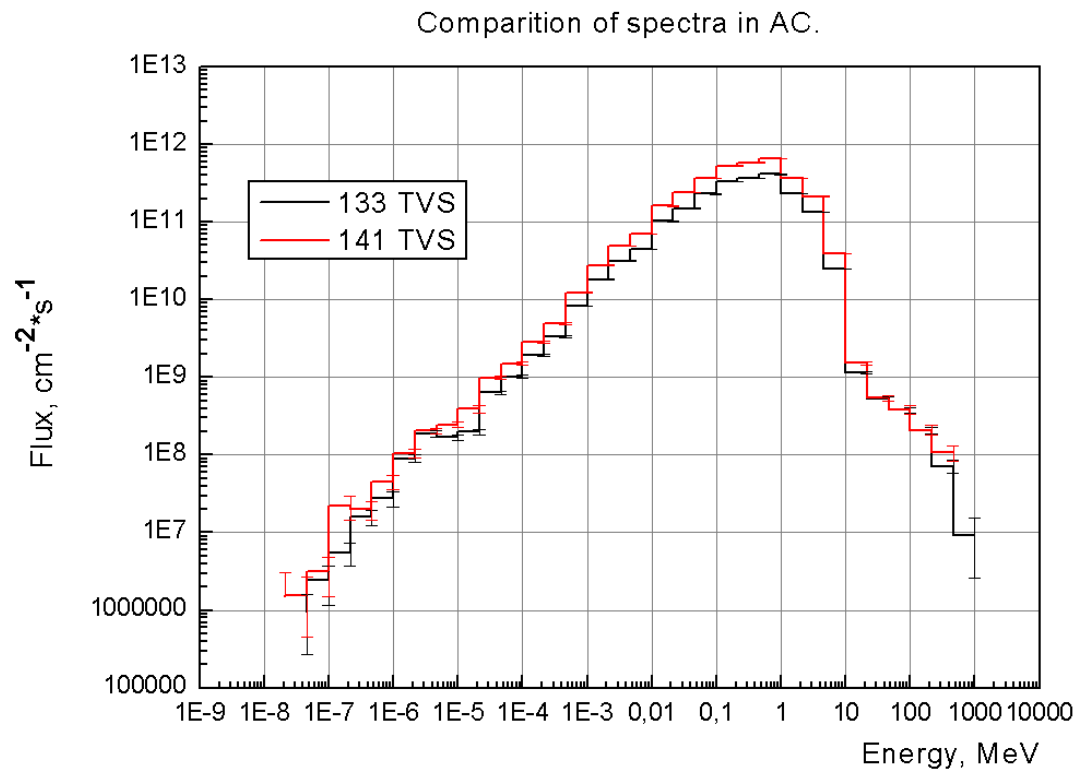

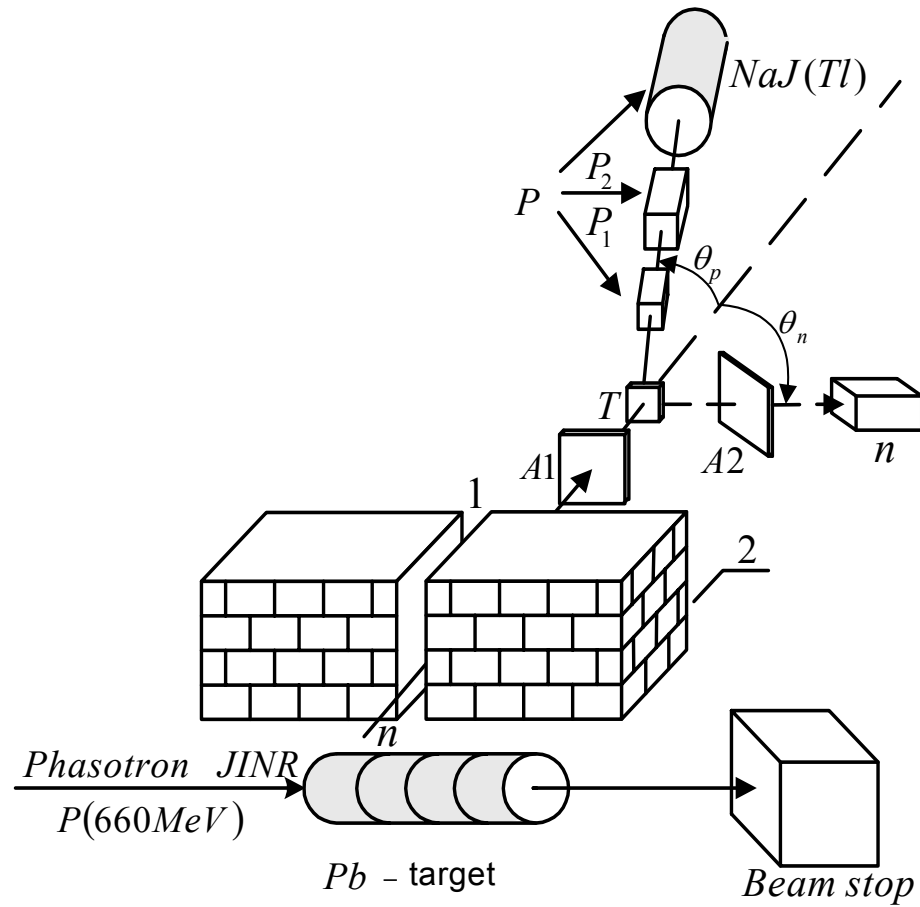
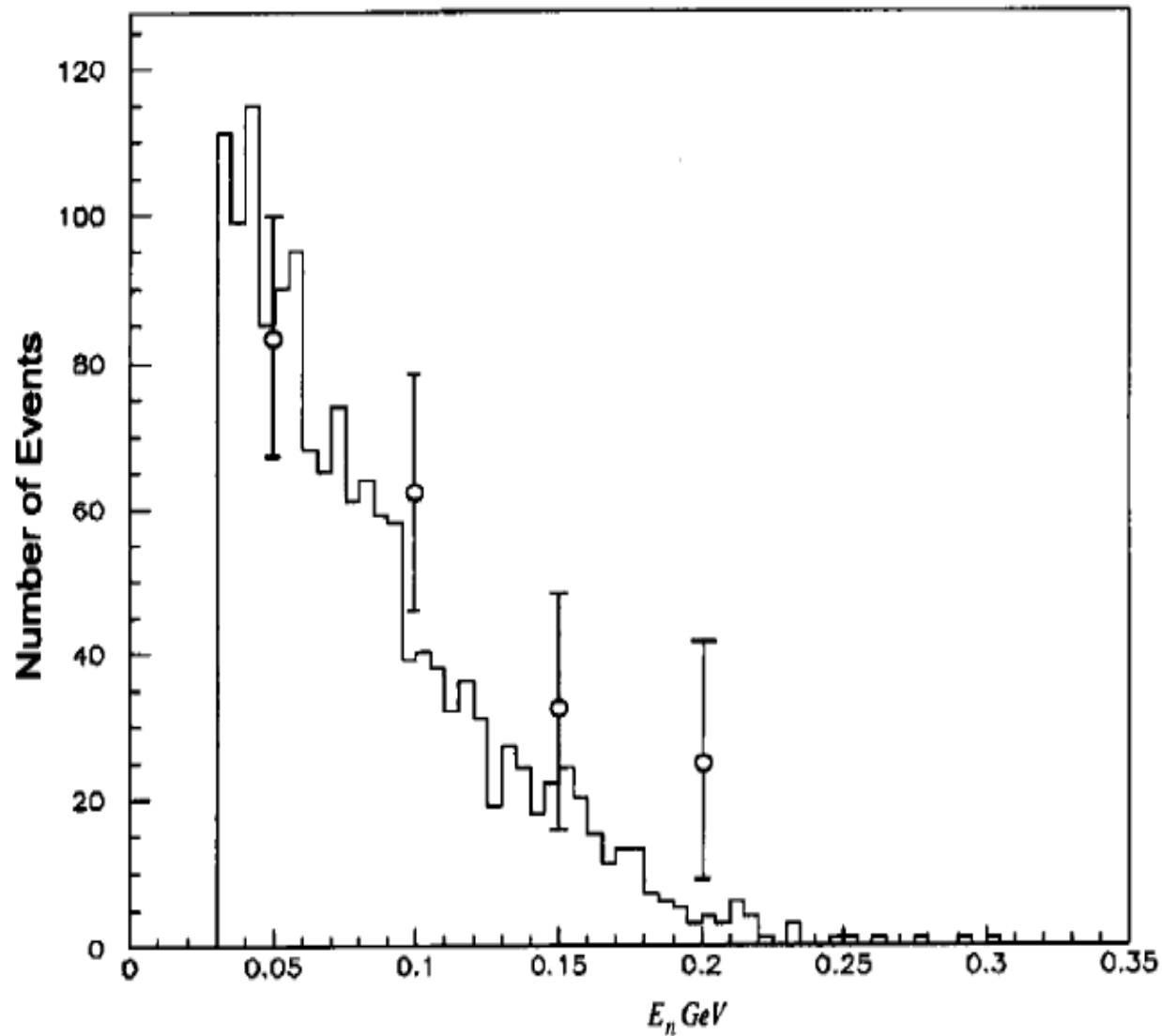

Fig. 2. The experimental set-up.



Energy spectrum of high energy neutrons emitted at 60 deg. from a lead extended target. Open circles-experiment results, histogram-GEANT simulation.

Go to [top](#)

Appendix 7

Booster (Cascade) Sub-critical Assembly

3rd SAD/YALINA Steering Committee Meeting
Dubna, June 27-28, 2005

“Booster (Cascade) Subcritical Assembly”

**S. Chigrinov¹, H.I. Kiyavitskaya¹, I. Serafimovich¹, V. Bournos¹,
Yu. Fokov¹, S. Korneev¹, S. Mazanik¹, A. Adamovich¹,
C. Routkovskaia¹, T. Korbut², A. Koulikovskaya¹, A. Khilmanovich²,
B. Martsinkevich², W.Gudowski³, H. Ait Abderrahim⁴, C.H.M.
Broeders⁵, A. Stanculescu⁶**

¹ Joint Institute for Power&Nuclear Research – Sosny
Sciences of Belarus

National Academy of Sciences of Belarus

⁴ SCK-SEN Belgium,

⁶ IAEA, Austria

² Stepanov' Institute of Physics National Academy of

³ RIT, Sweden

⁵ Forschungszentrum Karlsruhe
Institute for Reactor Safety

“EXPERIMENTAL THEORETICAL RESEARCH OF THE PECULIARITIES OF TRANSMUTATION OF LONG-LIVED FISSION PRODUCTS AND MINOR-ACTINIDES IN SUB-CRITICAL ASSEMBLY DRIVEN BY A NEUTRON GENERATOR” ISTC Project B-070

- **Application of low-energy ion accelerators coupled with sub-critical multiplying systems ($k_{\text{eff}} < 1$) allows to carry out the experimental research of different aspects of ADS-technologies and to outline future investigations at high energy particle accelerators.**

The main goals of the ISTC Project #B070

- creation the facility to investigate neutronics of a subcritical system driven by external neutron source;
- measurements of the transmutation reaction rates of fission products and minor actinides;
- investigation of kinetics of the sub-critical systems with external neutron sources;
- validation of the experimental techniques for, e.g., sub-criticality monitoring, neutron spectra measurement, etc;
- investigation of characteristics of sub-critical systems with the external neutron sources with pulse mode of neutron generator operation.

Joint Institute for Power&Nuclear Research – Sosny
National Academy of Sciences of Belarus

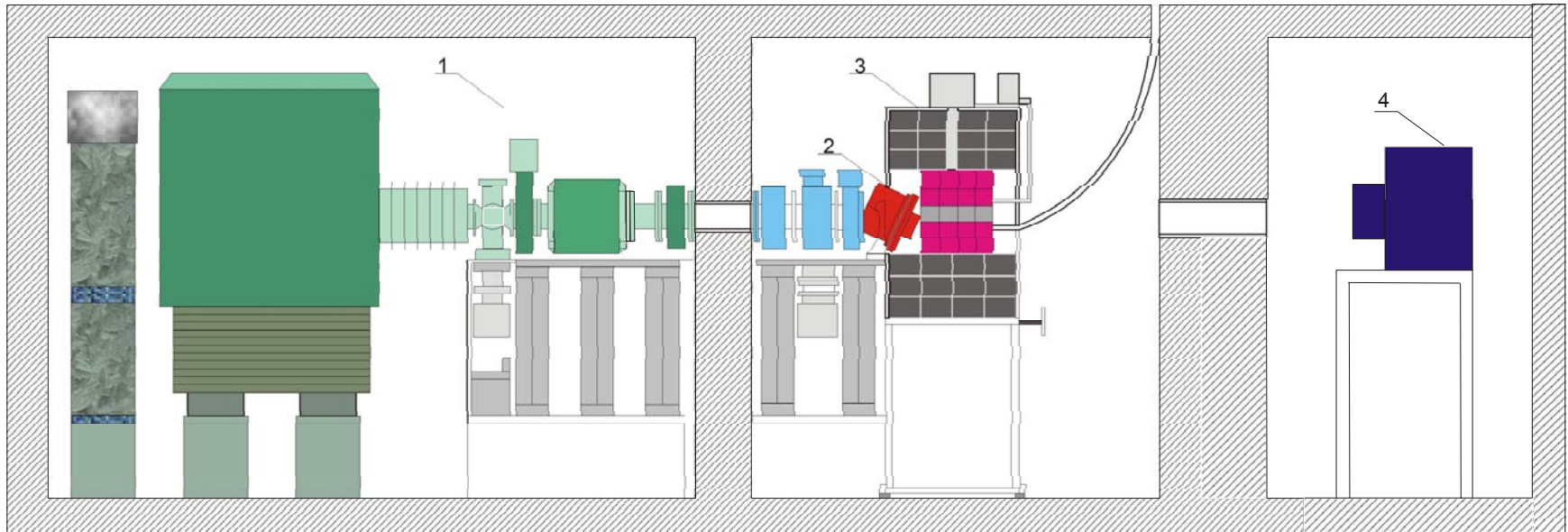

Sub-critical facility **YALINA**:

1 – neutron generator; 2 - Ti^3H (Ti^2H) target system; 3 -
sub-critical assembly, 4 - gamma-spectrometer

Joint Institute for Power&Nuclear Research – Sosny National Academy of Sciences of Belarus

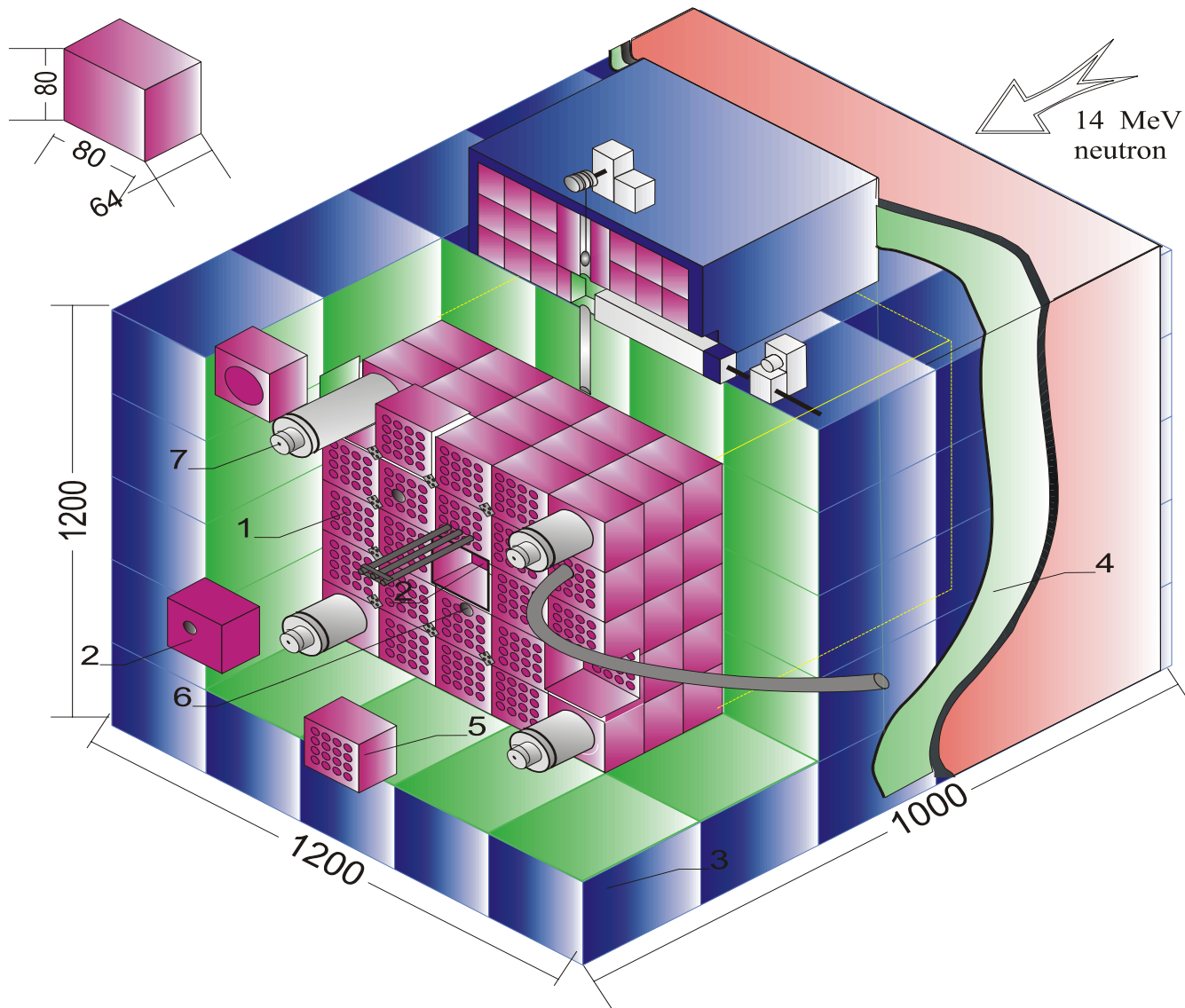

Uranium-polyethylene assembly

**Joint Institute for Power&Nuclear Research – Sosny
National Academy of Sciences of Belarus**

The core of the sub-critical assembly is a rectangular parallelepiped with **40.0 cm width, 40.0 cm height and 60.0 cm length**. It is assembled of polyethylene sub-assemblies with 16 fuel pins per sub-assembly, providing large flexibility of core configuration. The sub-critical core is loaded with UO₂ fuel dispersed in Mg matrix (uranium is enriched to 10 % by ²³⁵U). Fuel pins are arranged according a **square lattice with 2.0 cm** spacing. Central part of the subcritical assembly is a neutron producing **lead target of 8.0 cm width, 8.0 cm height and 60.0 cm length** and the core is surrounded by high purity **graphite reflector 40.0 cm thickness and with thin (l = 1.5 mm) Cd layer**.

**Joint Institute for Power&Nuclear Research – Sosny
National Academy of Sciences of Belarus**

YALINA fuel subassembly.

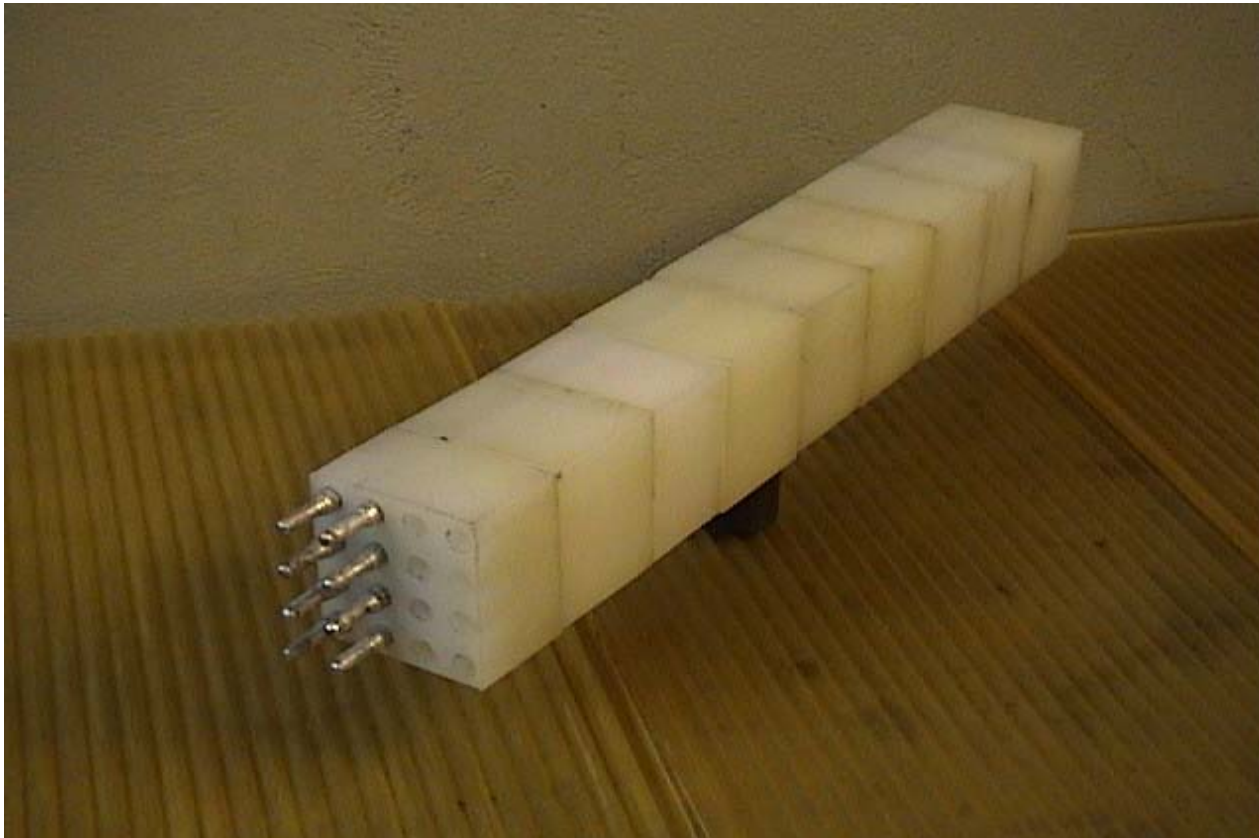

Joint Institute for Power&Nuclear Research – Sosny National Academy of Sciences of Belarus

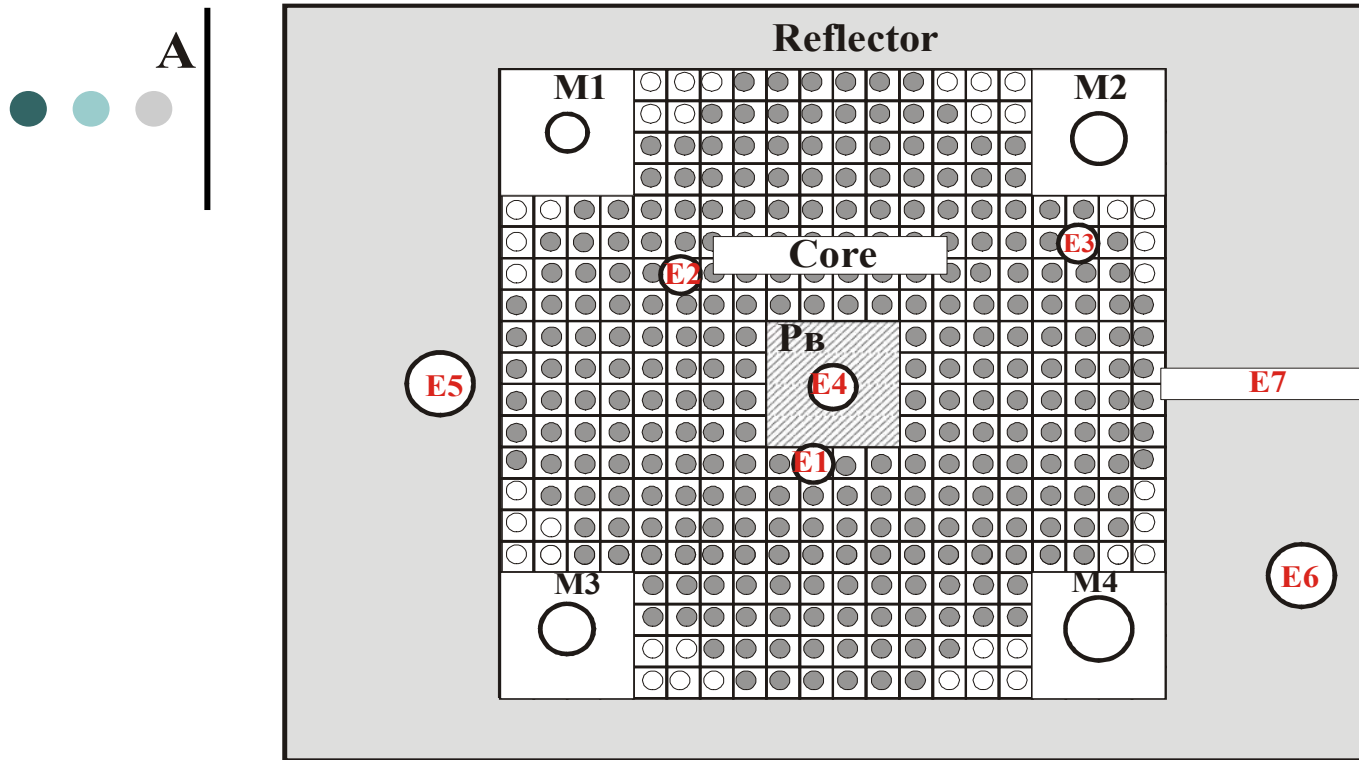

Uranium-polyethylene subcritical assembly

C - cross-section (280 fuel rods)

E1 - E7, M1 - M4 - experimental channels

Joint Institute for Power&Nuclear Research – Sosny
National Academy of Sciences of Belarus

- Neutron generator is linear accelerator of deuterium ions produced at duoplasmatron and accelerated to energy $E_d = 250$ keV. Accelerator magnet system separates D^+ ions only that by means of electro-magnetic lenses are directed towards the Ti^3H or TiD targets where in reactions $d(T,n)^4He$ and $d(D,n)^3He$ neutrons are generated with energies in the ranges $E_n = 13-15$ MeV and $E_n = 2.5-3.0$ MeV, respectively. At present highly effective water-cooled targets with diameters **230** and **45** mm are used in experimental program.

Monitoring of the neutron flux

GENEPI 2

Experimental platform PEREN at LPSC Grenoble

- Detection of the charged particles from $T(d,n)^4\text{He}$ or $D(d,p)^3\text{H}$ emitted backward
- Relative monitoring only because transmission of the beam line not well known

Absolute monitoring of the neutron flux

- Detection of the charged particles emitted backward by Si detector located at 0.8m of the target
- efficiency $\epsilon = 10^{-7}$ reliable because simply geometrical (no beam optics).

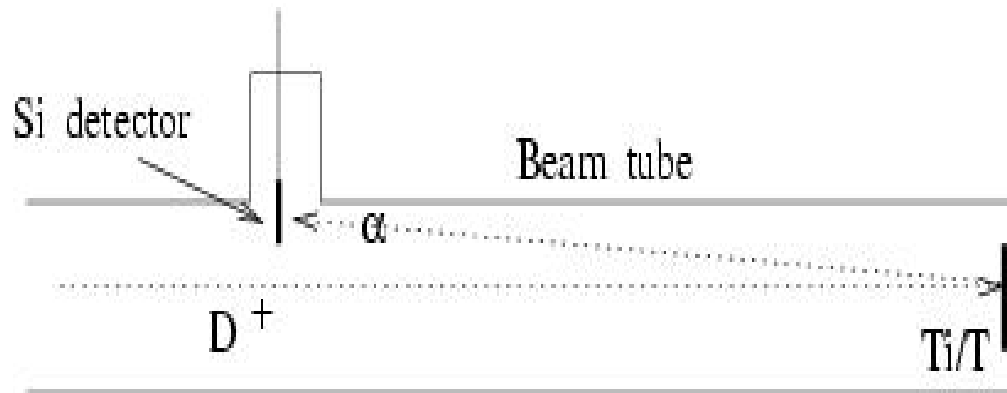

Joint Institute for Power&Nuclear Research – Sosny National Academy of Sciences of Belarus

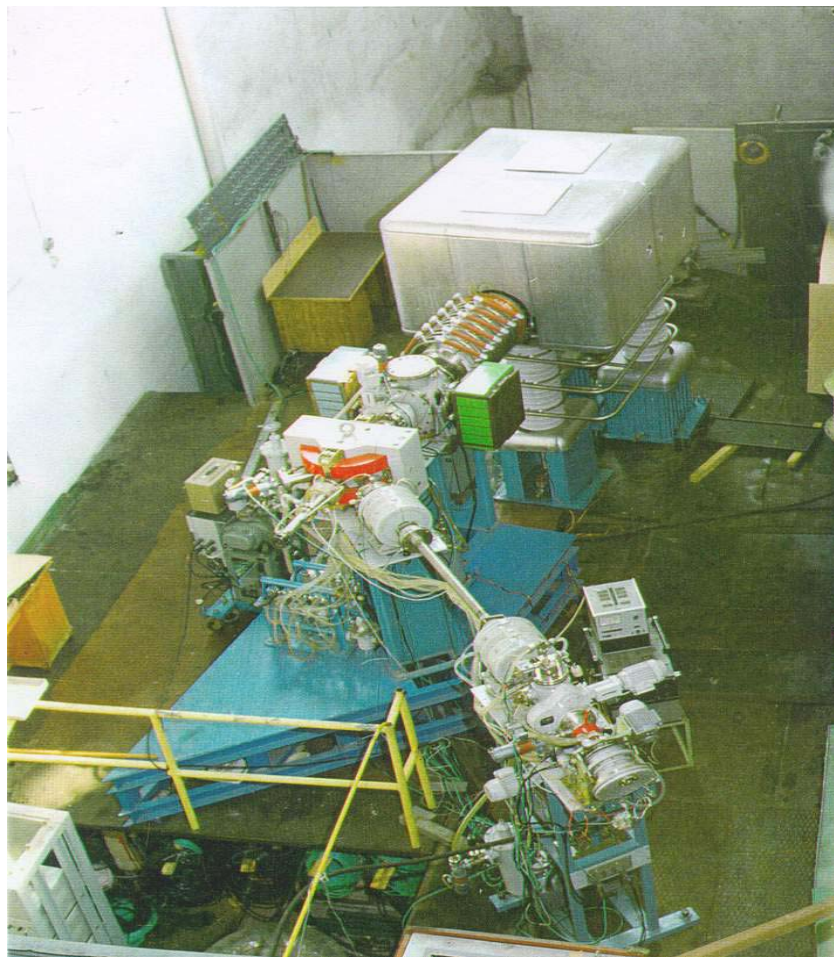

**Joint Institute for Power&Nuclear Research – Sosny
National Academy of Sciences of Belarus**

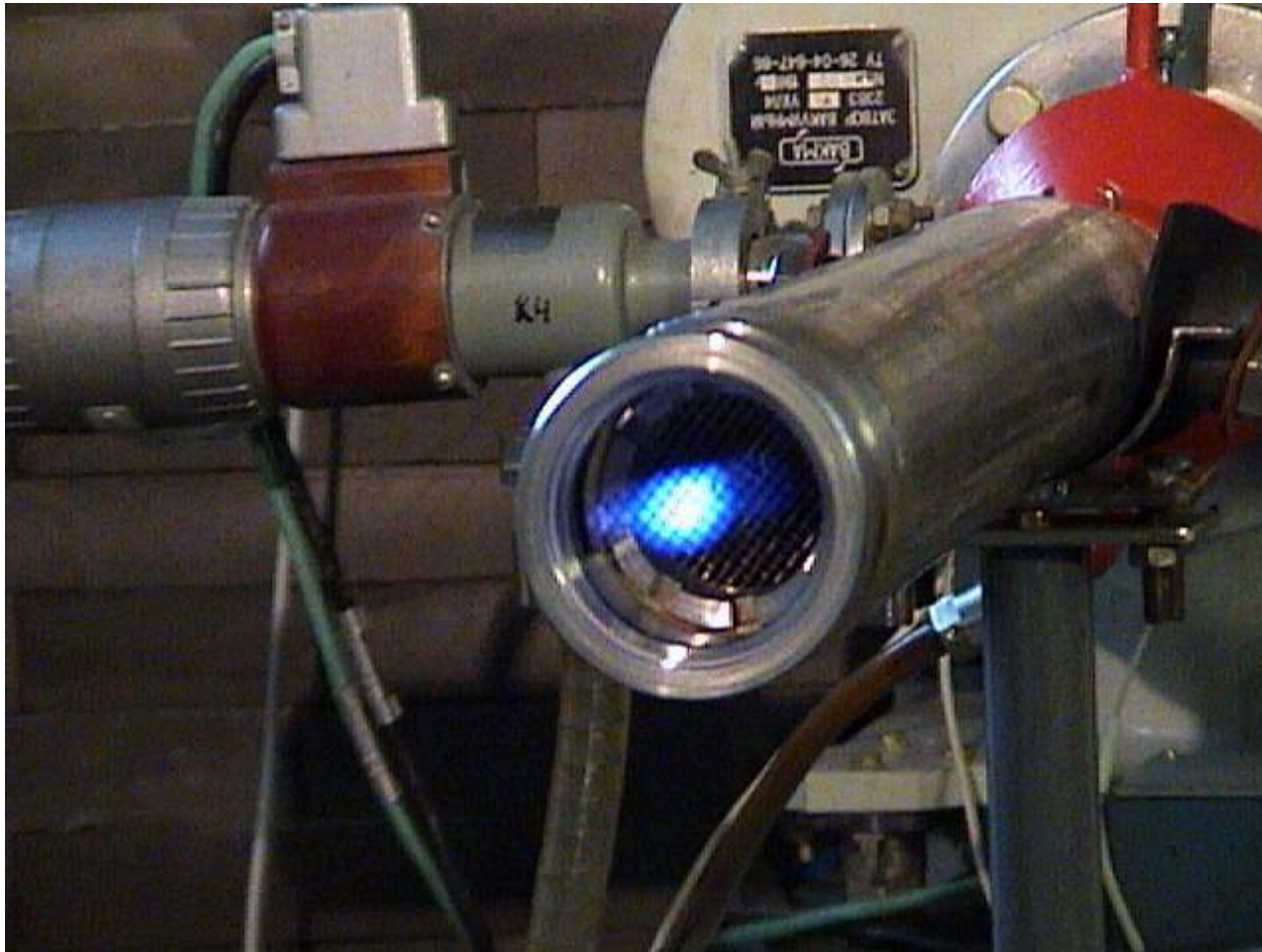

Joint Institute for Power&Nuclear Research – Sosny
National Academy of Sciences of Belarus

Target diameter

230 mm

Rotation speed

560 rpm

Diameter of reaction
space 100-200 mm

Tritium activity

0.53-0.75 MCi/kg

D/Ti (T/Ti)

atomic ratio

1.5-1.8

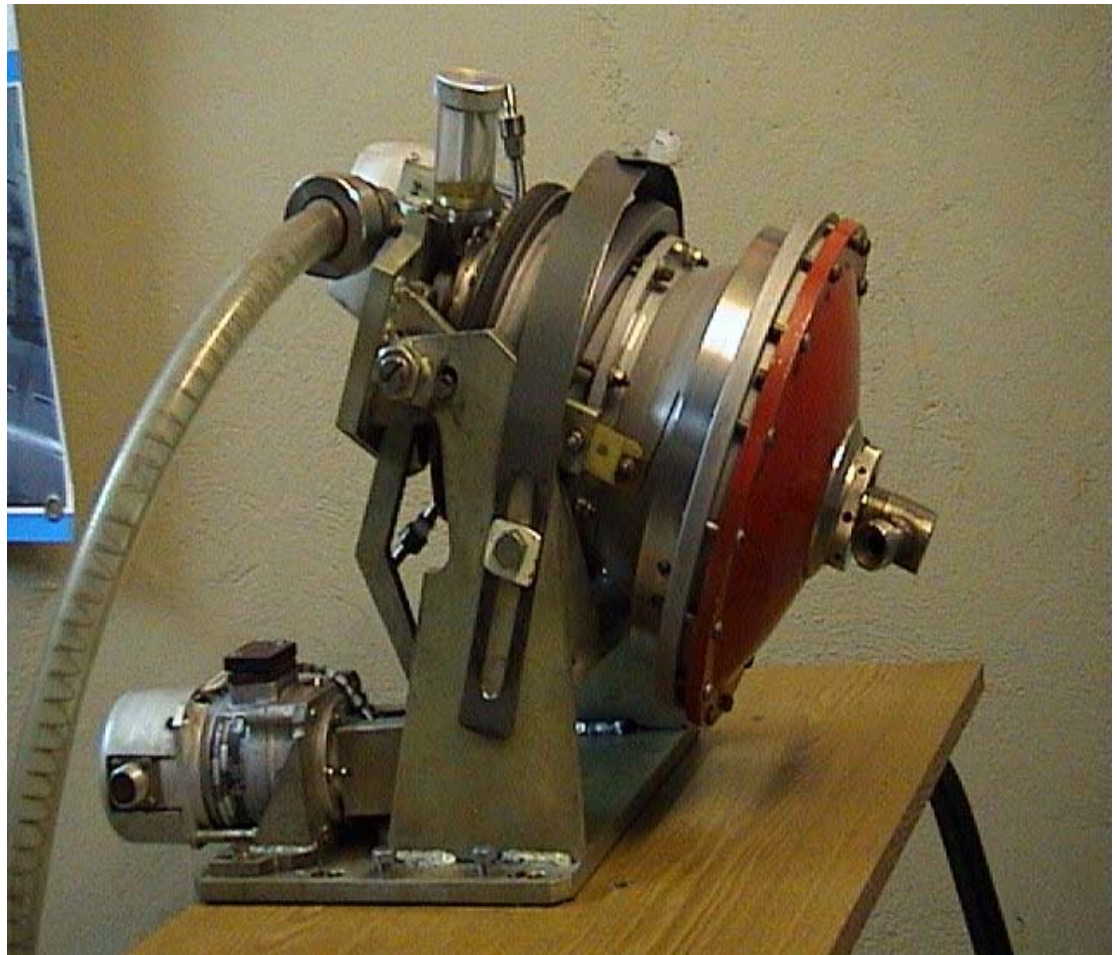

Joint Institute for Power&Nuclear Research – Sosny
National Academy of Sciences of Belarus

Accelerator	H+ and D+	
Beam energy	100 - 250 keV	
Beam current	1 - 12 mA	1 – 2 mA
Pulse duration	$(0.5-100) \times 10^{**(-6)} \text{ s}$	
Pulse repetition frequency	(1-10 000) Hz	
Spot size	2.0 -3.0 cm	
Ti³H target (230 mm		45 mm):
Rotation speed, rpm	560	-
Maximal yield of neutrons, n/s	$(1.0 - 1.5) \times 10^{12} \text{ n/s}$	$2 \times 10^{11} \text{ n/s}$
Neutron energy, MeV	13-15 MeV	
TiD target (230 mm	45 mm):	
Maximal yield of neutrons, n/s	$(2 - 3) 10^{10} \text{ n/s}$	$2 \times 10^9 \text{ n/s}$
Neutron energy, MeV	2.5 - 3	

Joint Institute for Power&Nuclear Research – Sosny National Academy of Sciences of Belarus

Subcritical Facility Yalina

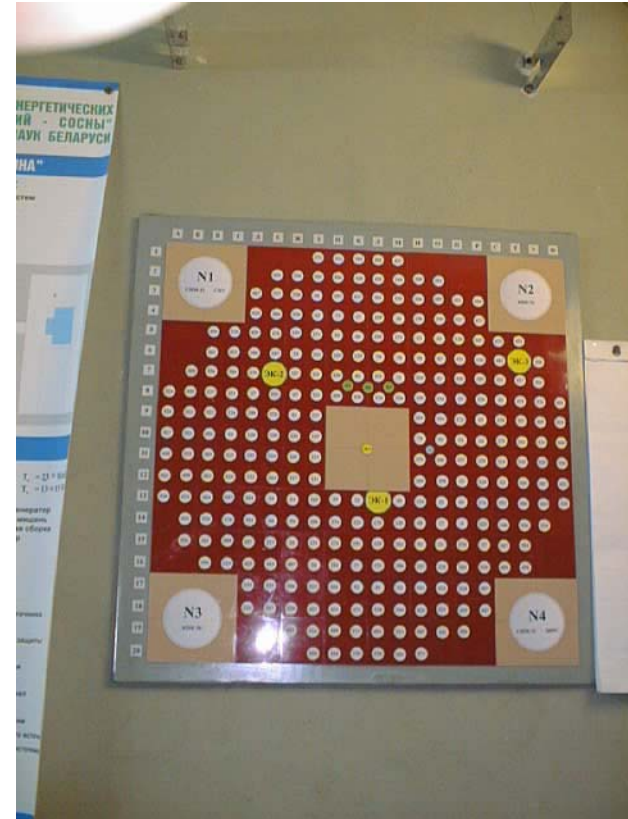

Joint Institute for Power&Nuclear Research – Sosny
National Academy of Sciences of Belarus

Energy distribution of neutrons flux (calculated) in the
sub-critical assembly Yalina.

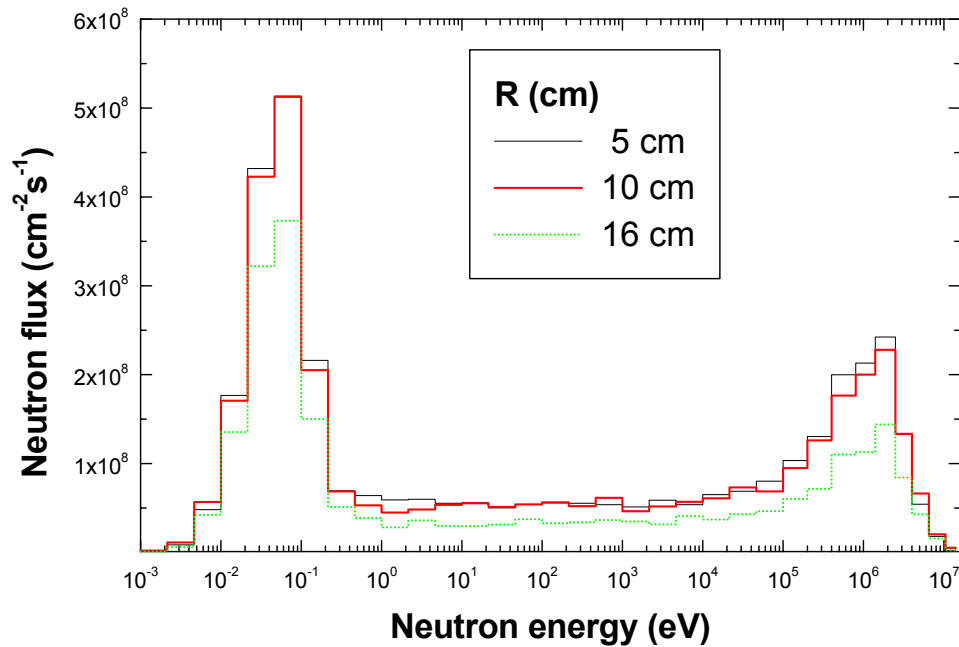

Joint Institute for Power&Nuclear Research – Sosny
National Academy of Sciences of Belarus

- Neutron generator is linear accelerator of deuterium ions produced at duoplasmatron and accelerated to energy $E_d = 250$ keV. Accelerator magnet system separates D^+ ions only that by means of electro-magnetic lenses are directed towards the Ti^3H or TiD targets where in reactions $d(T,n)^4He$ and $d(D,n)^3He$ neutrons are generated with energies in the ranges $E_n = 13-15$ MeV and $E_n = 2.5-3.0$ MeV, respectively. At present highly effective water-cooled targets with diameters 230 and 45 mm are used in experimental program.

Joint Institute for Power&Nuclear Research – Sosny
National Academy of Sciences of Belarus

**45 mm
target
unit**

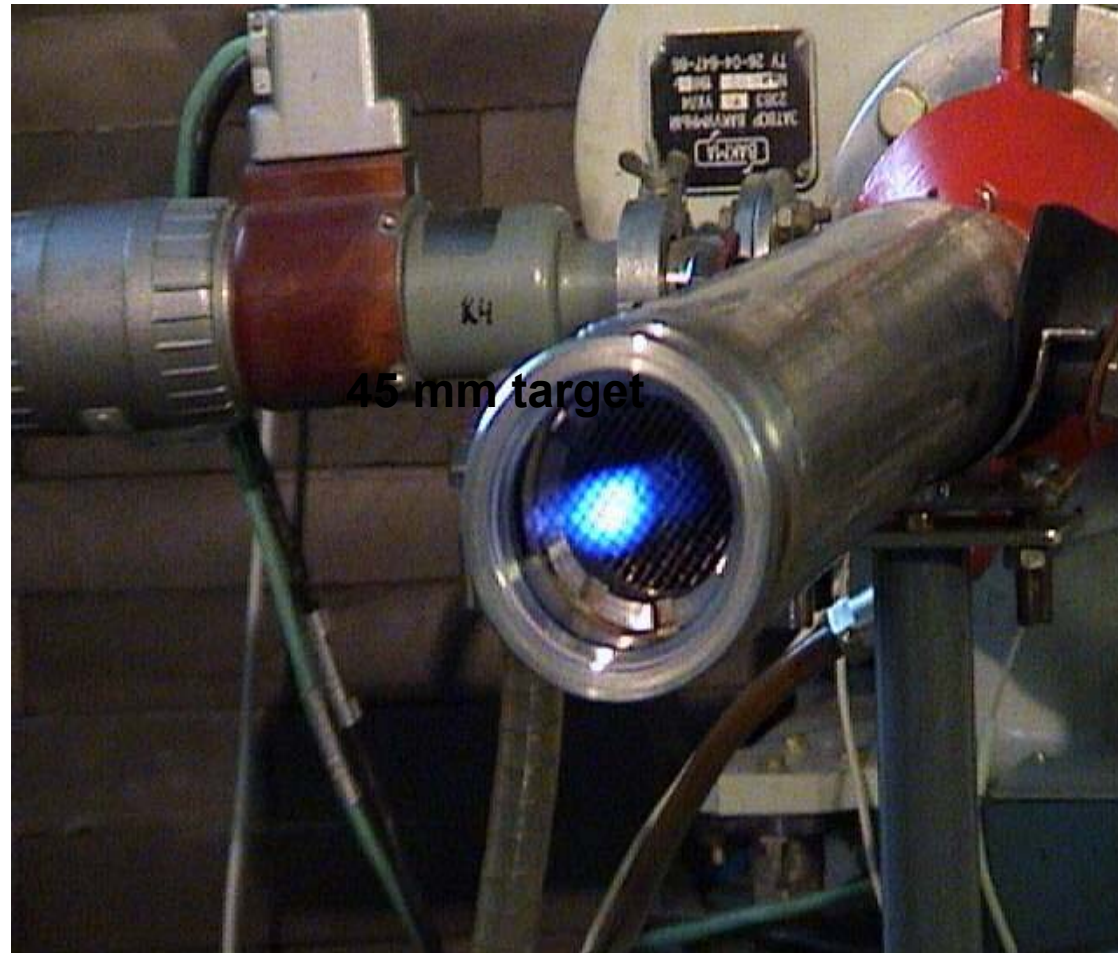

**Joint Institute for Power&Nuclear Research – Sosny
National Academy of Sciences of Belarus**

Target diameter

230 mm

Rotation speed

560 rpm

Diameter of

reaction space

100-200 mm

Tritium activity

0.53-0.75 MCi/kg

D/Ti (T/Ti) atomic

ratio 1.5-1.8

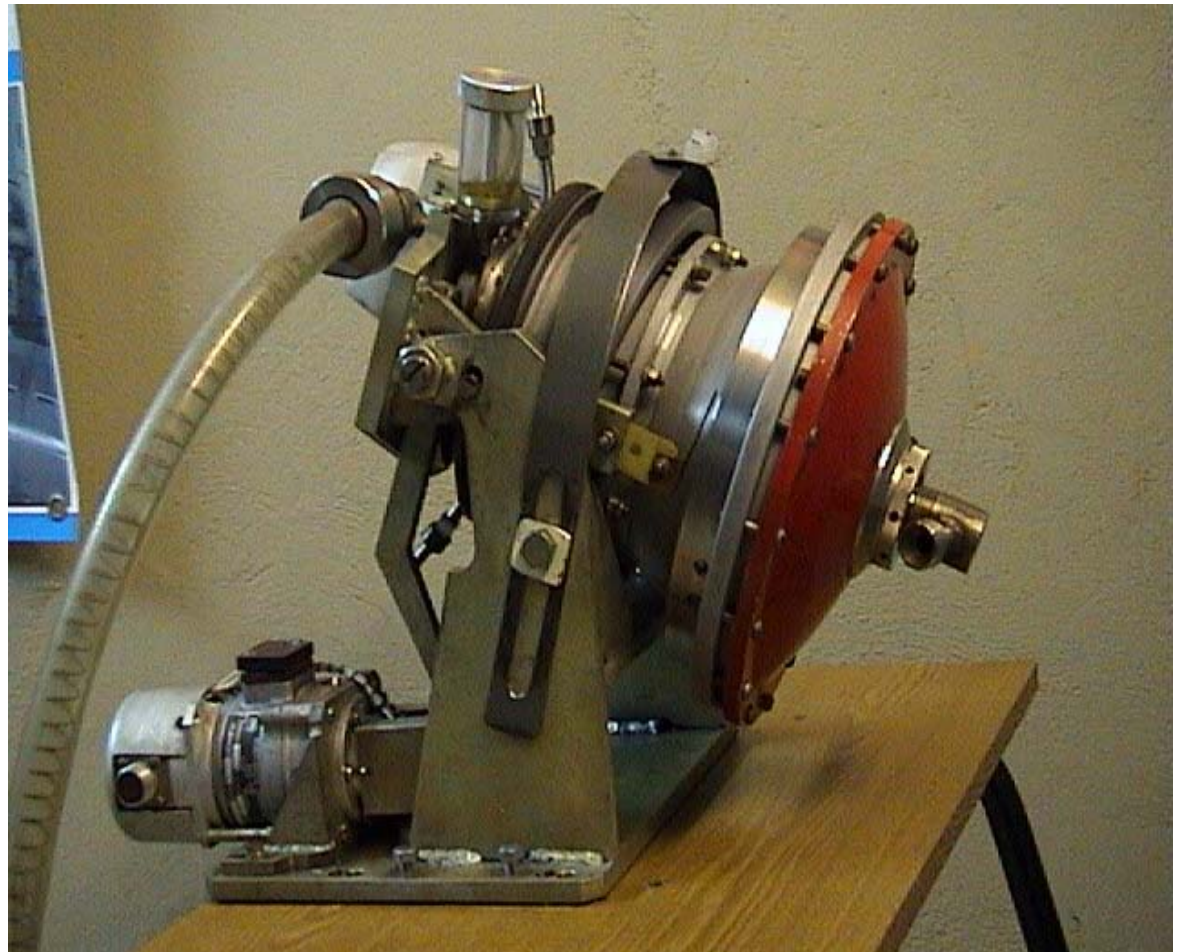

Main parameters of the neutron generator NG-12-1

Accelerator	H+ and D+	
Beam energy	100 - 250 keV	
Beam current	1 - 12 mA	1 – 2 mA
Pulse duration	$(0.5-100) \times 10^{**(-6)} \text{ s}$	
Pulse repetition frequency	(1-10 000) Hz	
Spot size	2.0 -3.0 cm	
Ti³H target (230 mm 45 mm):		
Rotation speed, rpm	560	-
Maximal yield of neutrons, n/s	1.0 x10 ¹² n/s	1.0x10 ¹¹ n/s
Neutron energy, MeV	13-15 MeV	
TiD target (230 mm 45 mm):		
Maximal yield of neutrons, n/s	(2 – 3) 10 ¹⁰ n/s	(2-3) 10 ⁹ n/s
Neutron energy, MeV	2.5 – 3	

Subcritical assembly with thermal neutron spectrum

$$K_{eff} = 0.98$$



Experimental and calculated reactivity of sub-critical assembly of various configurations

N_{pins}	<u>Pulse</u>	<u>Neutron method</u>	<u>Source</u>	<u>Gozani</u>	<u>Method</u>	kef (1/N)	<u>Sjöstrand</u>	<u>Method</u>	kef MCNP	Life time, μs (MCNP)
	α, s^{-1}	$\rho\alpha, \$$	kef $_{\alpha}$	ρ Goza-ni, \$	kef $_{\text{Gozani}}$		$\rho S, \$$	kef $_{\text{S}}$		
280	451.6 \pm 1.4	4.154	0.969	4.397	0.967	0.964	4.547	0.967	0.9715 \pm 0.0007	94.1
280-1 (centr)	473.1 \pm 1.7	4.399	0.968	4.844	0.964	0.962	5.205	0.962	0.9686 \pm 0.0007	94.4
280-2 (centr)	486.1 \pm 1.6	4.548	0.966	4.832	0.964	0.960	5.219	0.962	0.9665 \pm 0.0007	94.9
280-4 (centr)	519.6 \pm 2.0	4.930	0.964	5.365	0.960	0.955	5.898	0.957	0.9616 \pm 0.0006	95.99
280-1 (peref)	458.6 \pm 1.05	4.240	0.969	4.307	0.968	0.963	4.536	0.967	0.9703 \pm 0.0007	94.04
280-2 (peref)	468.4 \pm 1.1	4.346	0.968	4.442	0.967	0.962	4.595	0.966	0.9689 \pm 0.0007	94.3
280-4 (peref)	490.5 \pm 1.23	4.598	0.966	4.679	0.965	0.960	5.052	0.963	0.9672 \pm 0.0007	94.4

Joint Institute for Power&Nuclear Research – Sosny National Academy of Sciences of Belarus

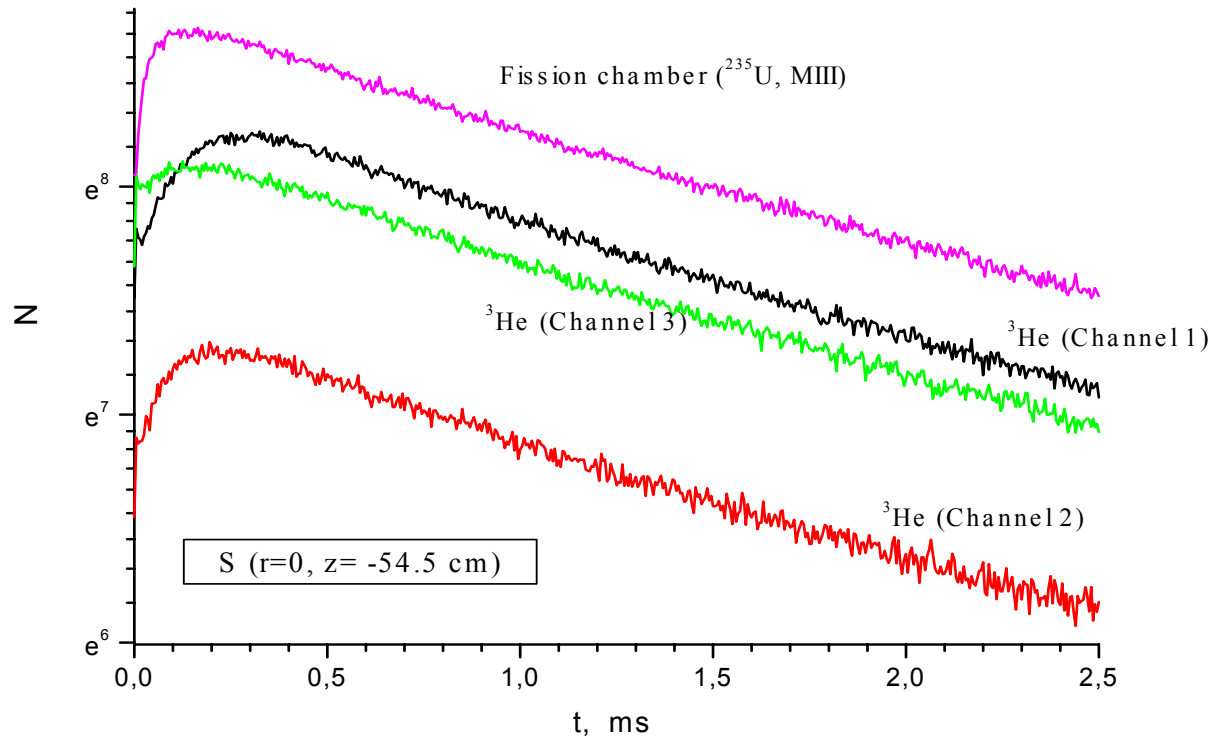

Time behavior of neutron flux density measured with application of ^{235}U fission chamber - CNT-5 and ^3He -detector in the experimental channels of the core loaded by $N_r = 280$.

Joint Institute for Power&Nuclear Research – Sosny
National Academy of Sciences of Belarus

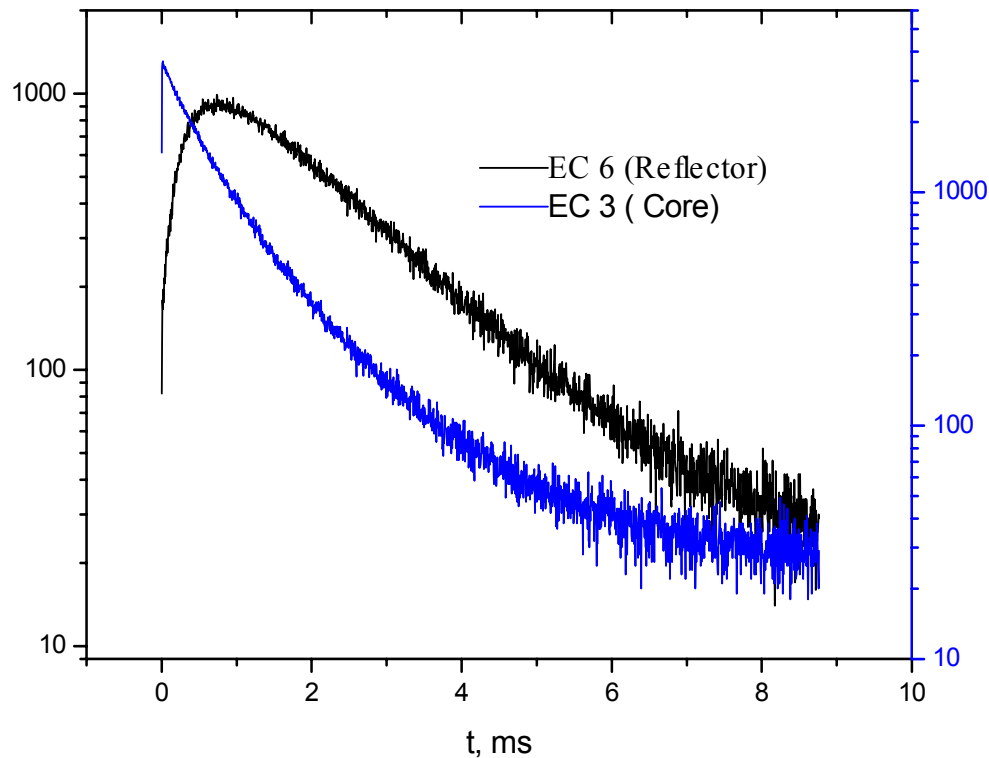

**Time dependence
of ^3He – detector
counting rates in
the
experimental
channels EC3
(core) and EC6
(reflector)
of the sub-
critical assembly
YALINA-Pb.
($\tau=7 \mu\text{s}$, 14 MeV)**

- Presence of the lead zone at the core center is the reason of remarkable variation of dN/dt distribution in the reflector due to moderation of neutrons formed in lead zone in $U(n,f)$ and $Pb(n,2n)$, $U(n,2n)$ reactions in high energy range.
- Thus the measurements of sub-critical system reactivity based on pulse neutron source method should be performed inside the core because contribution of source neutrons to neutron flux time behavior in reflector can be high enough to result in distribution different from $dN/dt \sim e^{-\alpha t}$ that follows from point kinetics approximation.

Np-237, Am-243 and I-129 samples

Sample	Activity, (10e+8) Bq	Mass, mg	Admixture
• NaI	0.044	1	< 17% I-127
• NpO ₂	0.113	366	< 0.2% Pu-239
• Am O ₂	1.100	14.8	< 0.2% Pu-239

**Joint Institute for Power&Nuclear Research – Sosny
National Academy of Sciences of Belarus**

- **Energy distribution of neutrons in the sub-critical systems is main parameter that defines most of ADS-technology characteristics and first of all transmutation of minor-actinides and long-lived fission fragments.**
- **Experimental measurement of neutron spectrum in such systems is non-trivial because of a great number of reactions in high energy range (n,xnyp) that to a great extent influence the shape of neutron energy distribution in the core.**
- **One of the main characteristics of thermal neutron spectrum is cadmium ratio R^{Cd} that demonstrates the contribution of thermal neutrons to the total neutron spectrum**

For determination of neutron energy spectrum at YALINA facility the following reactions were used:



Joint Institute for Power&Nuclear Research – Sosny National Academy of Sciences of Belarus

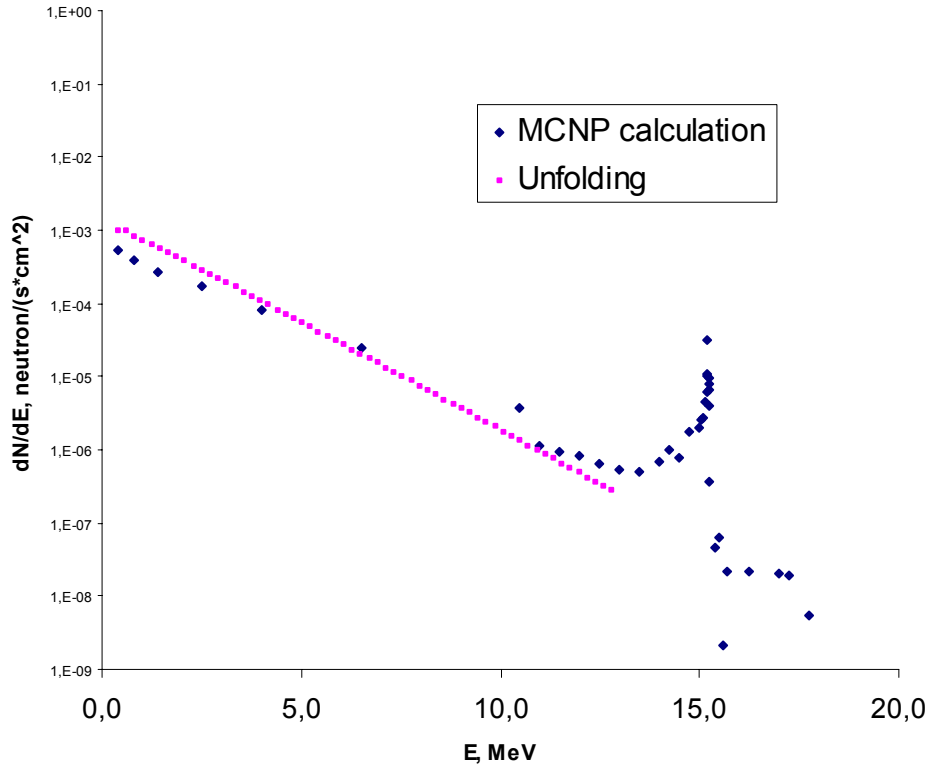

Comparison of neutron spectra in sub-critical assembly YALINA at the point $Z = 0$ cm and $R = 11$ cm calculated by MCNP-4B and unfolded by method of effective cross sections of threshold reactions using experimental data in the energy range 0.4 -13 MeV, per one neutron generated by NG-12-1 operating in (d,t) mode.

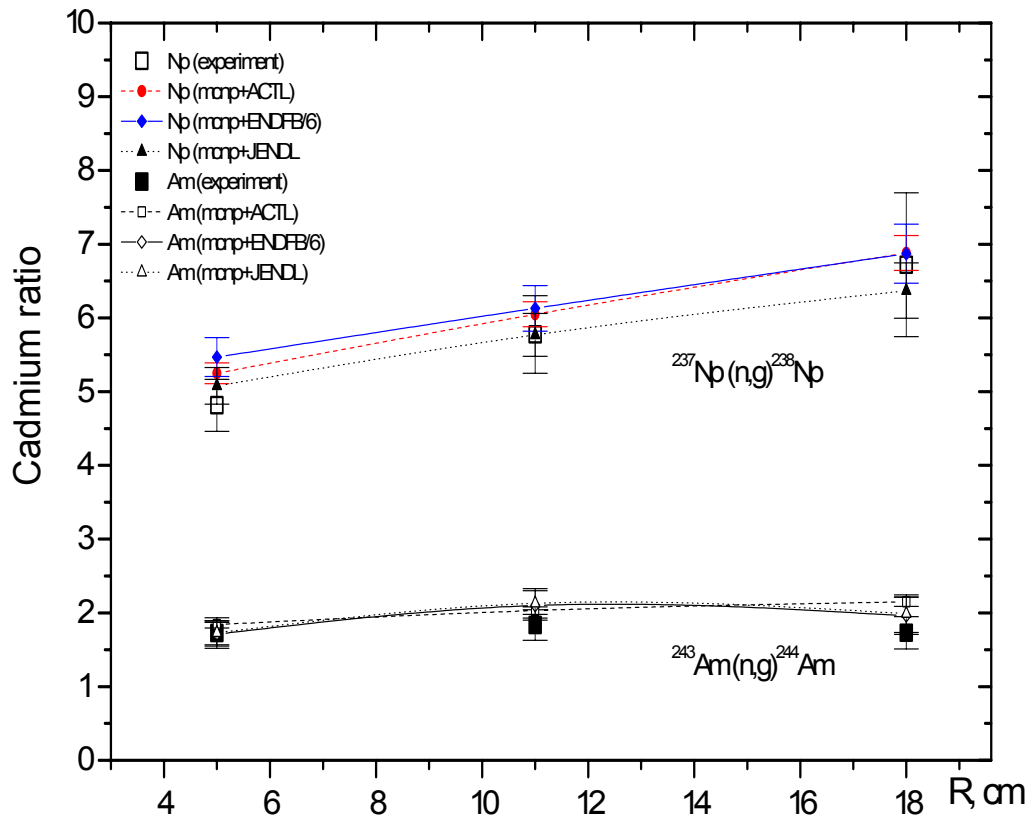

Experimentally measured and calculated cadmium ratios for $^{243}\text{Am}(n, \gamma)$ and $^{237}\text{Np}(n, \gamma)$ reactions by using ACTL, ENDFB/6 and JENDL libraries of evaluated nuclear data.

- In the frame of the B-070 Project an opportunity of investigation of various ADS characteristics at sub-critical assembly **Yalina** driven by neutron generator has been shown . The similarity of $d^2\sigma/d\Omega dE$ distributions in the energy range $E_n \leq 15-20 \text{ MeV}$ confirms a principal possibility of application of low energy accelerators as well as proton accelerators $E_p \leq 100...150 \text{ MeV}$ for investigations in the field of ADS-technology.

$K_{eff} = 0,975 - 0,98$

Booster zone ($K_{eff}= 0,60$):

48x48x50cm

FUEL: $X_5=90\%$ U met.

$X_5=36\%$ UO_2

$F(E_n > 0,1 \text{ MeV}) \sim 10^{**9} \text{ n}/(\text{cm}^2 \text{ s})$

moderator

Pb

Load (kg) $U_5-62.8; U_8 -54.5$

Intermediate zone

thickness, cm 3

material Umet ($X_5=0,7\%$) + B_4C

moderator Pb

load (kg) $U_5 - 0.23; U^8 - 31.8$

Thermal zone ($K_{eff}= 0,95$)

thickness, cm 24

fuel : $X_5 =10\%$ UO_2

Moderator polyethylene

reflector graphite

$F(th)$:

Ti3H –target $\sim 10^9 \text{ n}/(\text{cm}^2\text{s})$

Load (kg) $U_5 - 8.5; U_8 -72.6$

multiplication factor 50

Total load (kg) $U_5 \sim 72; U_8 - 167$

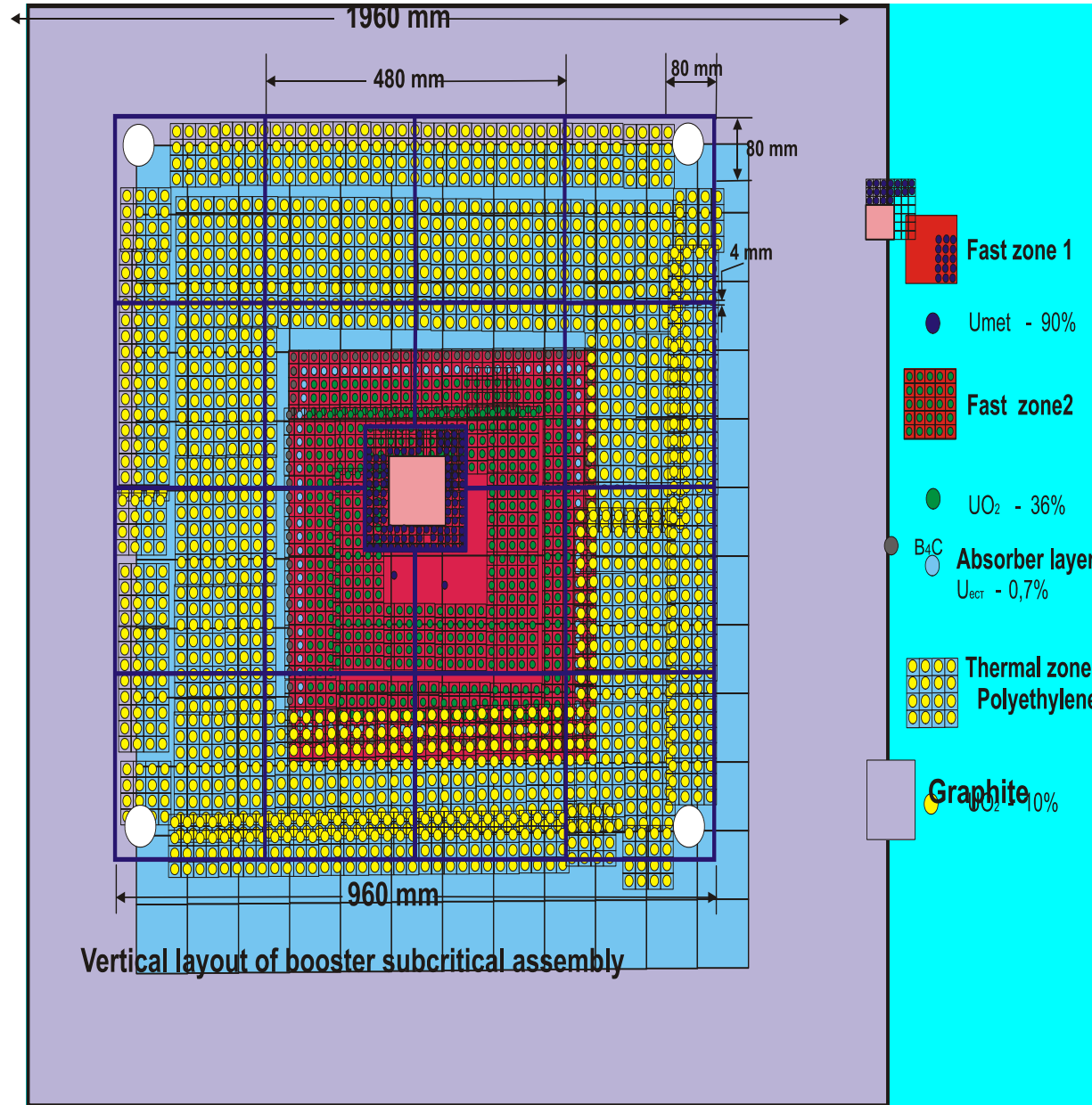

Joint Institute for Power&Nuclear Research – Sosny
National Academy of Sciences of Belarus

Booster (cascade) Subcritical assembly YALINA-B



Loading of fuel in Yalina-B assembly



Joint Institute for Power&Nuclear Research – Sosny
National Academy of Sciences of Belarus

Subcritical facility YALINA



Joint Institute for Power&Nuclear Research – Sosny
National Academy of Sciences of Belarus

The fast zone of the facility can be considered as a volume neutron source in contrast to YALINA and MASURCA experiments. From this point of view the booster zone is closer to the spallation lead target of the SAD and MYRRHA projects.

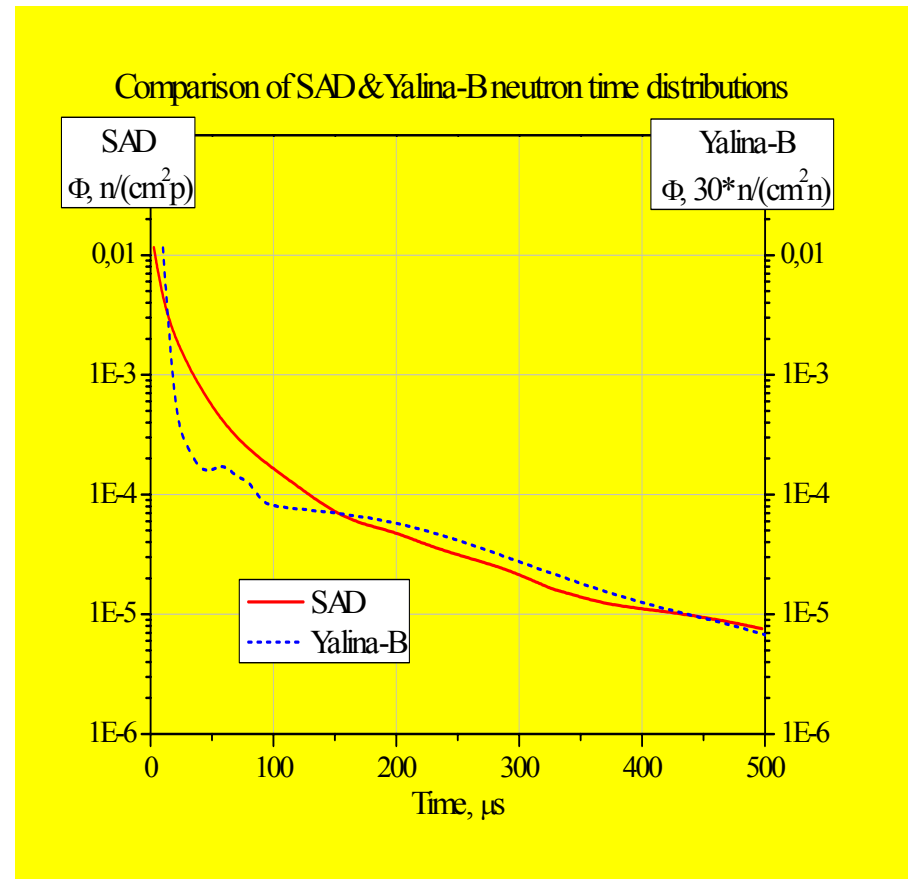
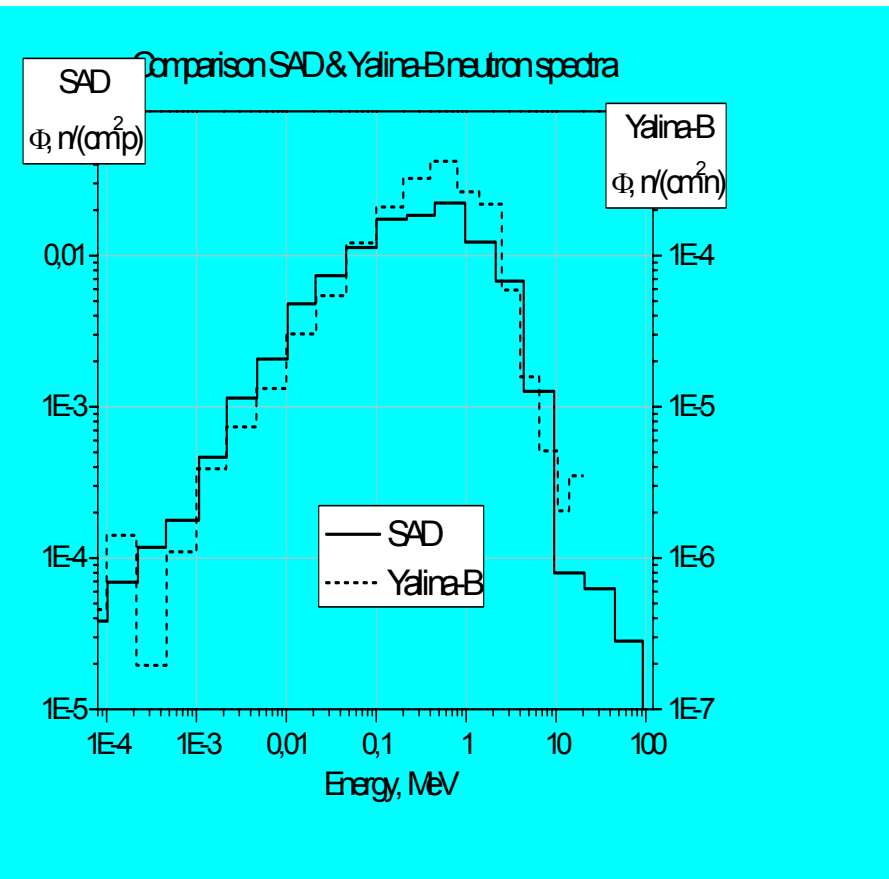

Prompt neutron lifetime in the booster subcritical assembly driven by a neutron generator:

SAD: A. Lopatkin $L = 24 \mu\text{s}$; E. Gonzales $L = 0.954 \mu\text{s}$;
 MUSE -3 $L = 0.61 \mu\text{s}$; MYRRHA $L=6.0 \mu\text{s}$.

	Bare booster zone	Booster zone with polyethylene reflector	Thermal zone with 1040 fuel pins	Booster assembly (832 pins in thermal zone)	Booster assembly (448 pins in thermal zone)	Booster assembly (1040 pins in thermal zone)
Prompt neutron lifetime	$5.6 \cdot 10^{-8} \text{ s}$ (0.056 μs)	$4.2 \mu\text{s}$ with B_4C in the intermediate zone $10.6 \mu\text{s}$ without B_4C in the intermediate zone	$6.2 \cdot 10^{-5} \text{ s}$ (62 μs)	$5.52 \cdot 10^{-5} \text{ s}$ (55 μs)	$4.9 \cdot 10^{-5} \text{ s}$ (49 μs)	$5.8 \cdot 10^{-5} \text{ s}$ (58 μs)
Neutron generation lifetime	$6.6 \cdot 10^{-8} \text{ s}$ (0.066 μs)	$7.3 \cdot 10^{-5} \text{ s}$ with B_4C $8.0 \cdot 10^{-5} \text{ s}$ without B_4C	$1.04 \cdot 10^{-4} \text{ s}$ (104 μs)	$8.4 \cdot 10^{-5} \text{ s}$ (84 μs)	$7.7 \cdot 10^{-5} \text{ s}$ (77 μs)	$9.5 \cdot 10^{-5} \text{ s}$ (95 μs)

MYRRHA-Yalina collaboration



Proposals on YALINA, SAD, MYRRHA experimental investigations

- Simulation of SAD and MYRRHA neutron spectra at the facility YALINA-B.
- Spectral indices, transmutation reaction rates measurements.
- Validation and development of the techniques of sub-criticality measurements in the neutron fields with time response characteristic for SAD facility (1/N, Sjöstrand, Source Jerk methods etc.)

Proposals on YALINA, SAD, MYRRHA experimental investigations

- Unfolding of neutron spectrum by the method of threshold reactions effective cross sections (fast neutron spectrum).
- Reactor oscillator and sub-criticality measurements at the facilities driven by external neutron sources.
- Detectors testing, validation of the experimental techniques intended for the measurements of neutron flux functionals.

Proposals on YALINA, SAD, MYRRHA experimental investigations

- Experimental measurements of neutronics in fast spectrum zone with different reflectors
(polyethylene, graphite, steel, beryllium).
- Monitoring of neutron yield from neutron-producing target.

Conclusion

The experimental facilities YALINA and YALINA-B allow to deliver valuable data in the following fields:

- measurements of transmutation rates of fission products and minor actinides,
- investigation of spatial kinetics of the sub-critical systems with external neutron sources,
- validation of the experimental techniques for, e.g., sub-criticality monitoring,
- neutron spectra measurement,
- safety research on sub-critical systems,
- technological applications such as, neutron activation analysis
- production of isotopes for calibration of gamma spectrometers etc.

Proposal of New Project

Project Proposal

....

Section 2. SUMMARY INFORMATION

1. Project title

Full title:

Experimental investigations of ADS physics, creation of the neutron sources for the purposes of fundamental and applied research on the basis of sub-critical assemblies with uranium fuel of high/low enrichment driven by neutron generator

Short title: creation of the neutron sources with uranium fuel of high/low enrichment

Technology area:

Hybrid systems and fuel cycles FUS-HSF
Atomic and nuclear physics PHY-ANU

Category of Technology Development:

Fundamental and applied researches

Go to [top](#)

Appendix 8

Potential SAD activities with significant contribution from EU partners

Potential SAD activities with significant contribution from EU partners

D. Villamarín and E. González
CIEMAT

BFS experiments during SAD construction

- Design of the most suitable BFS configurations
- Set-up of the selected configurations
- Calibration of the detectors and electronic chains present in BFS
- Transport and tuning to BFS of the data acquisition systems used during the MUSE experiments
- Calibration and monitoring of the (D-T) source during the experiments
- Determination of the kinetic parameters of the system in the critical configuration
- Kinetic experiments in subcritical configurations with $k_{eff} = 0.95$ and 0.97
- Analysis of the experimental results
- Detailed description of the configuration to be used as international benchmark (simulation code calibration)
- To study the possibility to load BFS with the SAD fuel in a critical configuration in order to determine the kinetic parameter k_{eff} of SAD fuel.

Start-up experiments using the (D-T) source

- Design of the two configurations
- Set-up of the configurations
- Calibration of the detectors and electronic chains present in SAD to work with low intensity source (pulse mode)
- Transport and tuning to SAD of the data acquisition systems used during the MUSE and BFS experiments
- Calibration and monitoring the (D-T) source
- Validation of the thermal neutron shielding for diagnostic techniques
- Estimation of SAD kinetic parameters with the simulation tools calibrated at BFS
- Kinetic experiments in the subcritical configuration to determine the reactivity of the system
- Analysis of the experimental results
- To study a core heating system to perform the kinetic experiments at the same temperature conditions that will be found with the proton accelerator

Test and calibration of the actual spallation target outside SAD

- Dedicated off-core cooling system for the spallation target
- Set-up of the same detector systems as in the previous target experiments
- Measurement of the neutron source intensity and energy distribution

Experiments using the 660 MeV proton accelerator (I)

- Determination of the detectors and electronic chains required in SAD to work at full power
 - Using fast extraction
 - Using slow extraction
- Calibration of the detectors and electronic chains at full power
 - Using fast extraction
 - Using slow extraction
- Development and validation of new data acquisition systems adapted to work with current mode detectors for kinetic measurements
 - Using fast extraction
 - Using slow extraction
- Definition of experiments
 - Using fast extraction (area method, slopes method)
 - Using slow extraction (source jerk, integrated slopes method, power to reactivity method)
 - Simulation support for the experiments

Experiments using the 660 MeV proton accelerator (II)

- Monitoring of the accelerator and the importance of the source
 - Online monitoring of the beam current
 - Monitor the number of neutrons per proton (part of source important)
 - Monitor the geometric distribution of primary neutron source (diagnostics for source importance)
- Neutron fluence determination across large thickness shielding
 - Definition and set-up of the detectors
 - Measurement of the neutron fluence after lead, concrete and iron shielding
 - Comparison with the results obtained by simulation codes
- Determination of the effects of using the thermal neutron shielding in the kinetic experiments

Experiments using the 660 MeV proton accelerator (III)

- Kinetic experiments using fast extraction mode of the accelerator: area method and slopes method
- Kinetic experiments using slow extraction mode of the accelerator: source jerk and integrated slopes method
- Calibration of SAD power
- Determination of the techniques that will be used to calibrate the power to reactivity technique
- Experiments of power to reactivity online monitoring
- Feedback experiments
 - Temperature variation of the fuel
 - Fast reactivity variation using insertion or extraction of absorbers
 - Oscillation of reactivity with absorbers and/or fissile material
- Static and kinetic measurements of the axial and radial(?) fission rate traverses to validate simulation codes
- Interpretation of the experimental results

Similarities and differences between the experimental results in different conditions

- Extensive simulations should allow the calibration of simulation tools and the study of the correlation between the different reactivity determination techniques

Post-irradiation experiments

- Extensive post-irradiation program to determine the spallation fragments in the target and fission products in the fuel
- The experimental results will be used to validate simulation tools and for international benchmarking

Go to [top](#)

Appendix 9

The following action plan was agreed:

1. Letters of intent of JINR to cooperate in the EUROTRANS project will be prepared until July 9, 2005 (V. Shvetsov).
2. Letters of intent of ISTC to support the continuation of ISTC Project #2267 SAD in the framework of EC FP 6 IP EUROTRANS DM2 ECATS have to be prepared in July 2005 (W.Gudowski, L .Tocheny, V. Shvetsov).
3. On the basis of the letters of point 1) and 2) written agreement between JINR, ISTC and EUROTRANS must be established in due time (W.Gudowski, L .Tocheny, V. Shvetsov, C. Broeders).
4. The required documents for the SAD/YALINA related work program of EC IP EUROTRANS DM2 ECATS will be prepared before August 31, 2005 (C. Broeders, W. Gudowski).
5. For the near future more frequently (tentatively every 6 weeks) SAD/YALINA SCM are envisaged.
6. Efforts to broaden the international support for the SAD experiment are encouraged (all), more specifically USA DOE (W. Gudowski) and Japan (C. Broeders)

Go to [top](#)